

Model LS-850-05 High Performance Limit Switch

The SVF "LS850" is a rugged and compact position indicating device that incorporates the latest in design technology featuring and a new aerodynamic look with the added flexibility to meet a variety of control needs.

Product Features

- Rugged and Compact design
- Quick-Set cam is spring loaded and does not require any special tools
- Dual Cable Entries to facilitate wiring in the field and of the addition of ancillary devices (Pilot Valve)
- Captive Cover Bolts will not get lost during commissioning
- NAMUR mounting for universal use
- Selection of Mechanical or Proximity switch/sensors



SPECIFICATIONS	STANDARD	OPTIONAL	MATERIALS	
Enclosure	Weatherproof NEMA 4/4X (IP67)	IP68 Submersible	Housing	Aluminum
Ambient Temp.	-4 F to 176 F (-20 C to 80 C)		Shaft	Stainless Steel
Conduit Entry	2 X 1/2" NPT	Metric	Indicator	Polycarbonate
Terminal Strip	8 points		Cam	Polycarbonate
Position Indicator	CLOSED (Red), OPEN (Yellow)	CLOSED (Red), OPEN (Green)	Spring	Stainless Steel
Switch elements	2 X Mechanical SPDT	2 X Proximity Sensor	Housing Cover Fastener	Stainless Steel
External coating	Polyester Powder coating (Silver)	(Black)	O-Ring	NBR
Shaft	Length 17 mm to NAMUR	Specify	Bushing	Bronze
			Shaft C-Clip	Stainless Steel
			Grounding Screw	Stainless Steel
			Bracket	Stainless Steel

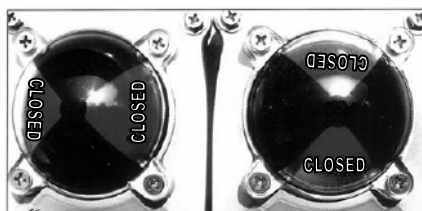



Position Indicator may be Re-Positioned for specific rotary indication or for use with Linear Valves or Actuators

Product Details

- Dual Cable Entries to facilitate wiring in the field and of the addition of ancillary devices (Pilot Valve)
- Captive Cover Bolts will not get lost during commissioning

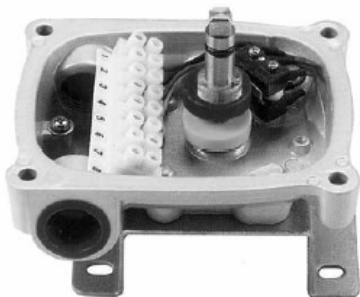

Mechanical Switch (2 X SPDT)	Proximity Sensor
	
<p>Standard Switch: Omron #SS5GL Type: SPDT Wired Contact Rating: 250VAC-3A, 125VAC-5A, 250VDC-0.2A, 125VDC-0.4A, 30VDC-4A</p> <p>Approval Standards: UL, CSA, SEMKO, SEV EN61058-1</p>	<p>Standard Sensor: P&F NJ2-V3-N Type: Inductive Proximity Sensor (intrinsically safe) Voltage Rating: 8VDC (IP67 to IEC 60529) Operating Distance: 2mm</p> <p>Approval Standards: EN 60947-5-2</p>

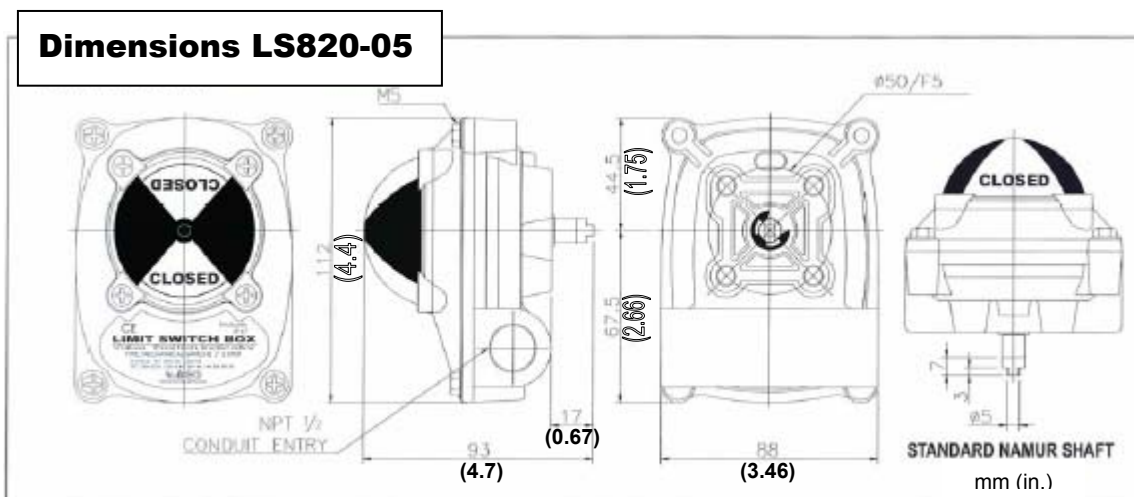

HOW TO ORDER

Standard Model is LS820-05

Limit Switch	Model	Amps	Enclosure	Switch	BKT
LS	850	-05 (5 AMP)	BLANK (NEMA 4/4X (IP67))	BLANK (2 X SPDT MECH)	-1 (0.78)
		-10 (10 AMP)*	-IP68 (SUBMERSIBLE)*	-PS (PROX SENSOR)*	-2 (1.18)
			HAZARDOUS AREA (SEE PROX SW. (IS))		Actuator Stem Height

* contact SVF for optional offering