

# SVF Flow Controls, Inc.

## 31/41 Series

Including Jacketed Valves (J31/J41)

# Installation, Operating & Maintenance

## Flanged Ball Valves

### Series Included:

31/41

### Sizes Included:

1/2" - 8" (DN15 - DN200)

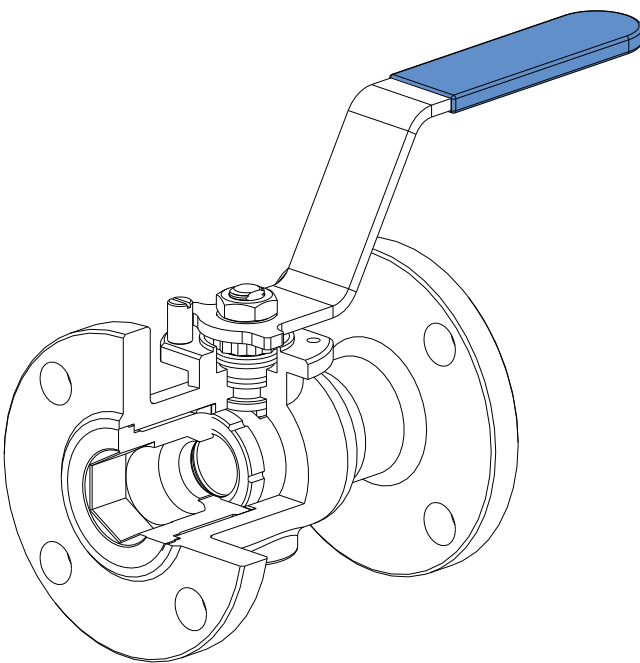

### 1. GENERAL

This Installation, Operating & Maintenance manual covers the instructions required for safe use of SVF flanged ball valves type 31/41 series.

The manual relates to one piece reduce bore flanged ball valves. Before using a valve, read the entire IOM carefully and make sure you understand everything.

### WARNINGS & SAFETY INSTRUCTIONS

SVF cannot anticipate all of the situations a user may encounter while installing and using SVF valves. The user **MUST** know and follow all applicable industry specifications on the safe installation and use of these valves. Misapplication of the product may result in injuries or property damage. Refer to SVF product catalogues, product brochures and installation, operating and maintenance manuals for additional product safety information or contact SVF.

1. Keep hands and objects away from the valve ports at all times. Actuated valves could be accidentally operated, resulting in serious injury or valve damage.
2. Before removing a valve from the line always make sure the line has been depressurized and drained. Cycle the valve a few times to relieve any pressure that could be trapped in the body cavity.
3. Utmost caution must be taken when handling a valve that has toxic, corrosive, flammable or a contaminant nature media flowing through its pipeline. The following safety precautions are recommended when dismantling valves with hazardous media:
  - a. Wear eye shield, protective headgear, clothing, gloves and footwear.
  - b. Have available running water.
  - c. Have a suitable fire extinguisher when media is flammable.
4. Do not try to operate a valve that exhibits any sign of leakage. Isolate the valve and either repair or replace it.
5. Do not use or substitute non SVF components or parts in SVF valves and assemblies.

## 2. LIMITATIONS

The correct selection of materials of construction, seats and seals, internal valve components and pressure/temperature ratings determines the safe use of the valves and the particular performance requirements for the application. This information can be found on the nameplate welded to the valve body.

The combined **corrosion** and **erosion** allowance for the valve body wall thickness is 1 mm. When this allowance has gone, the valve should no longer be used. Inspect the valve wall thickness every time the valve is maintained. Refer to SVF Corrosion Data Chart T-614 to determine the corrosion rate for your application.

As the extent of applications these valves can be used in is large, it does not make it possible to cover all installation and maintenance instructions to service the valves. It is the owners responsibility to use the valves as recommended and in accordance with the pressure and temperature limits as stated in this manual. Where in doubt, please consult with SVF. Any unstable fluid or gas should be identified by its manufacturer and must not be used with SVF valves.

### CAUTION:

The valves should be used in a well designed, adequately protected system to **ensure that external and internal pressure and temperature limits are not exceeded**. The valve body rating can be higher than the seat rating. Valve surface temperature may become extremely hot or cold due to ambient or operating conditions. Prevent any type of direct contact with the valve that may harm the workers. Wear protective gloves.

The valves should be used in a well designed, adequately supported piping system such that it will not be subjected to undue forces and moments during service. Avoid shock loads (water hammer). The valves are not designed to operate during or after earthquakes or under fatigue conditions. It is the responsibility of the owner to determine if fatigue conditions exist.

**Do not allow dust layers to build up on the apparatus.**

## 3. STORAGE

Prior to storage, inspect the valve for shipping damage. Keep all protective packaging and flange covers attached to the valves during storage. It is recommended to keep the valves in a clean and dry environment until ready for use.

Carbon Steel valves have a "black oxide" and oil dipped finish. This nontoxic process is performed to retard rusting during storage. It is not a substitute for paint or other means of protective coating to be applied to the valve once installed.

Stainless steel valves have their natural finish and do not need any additional protection once installed.

## 4. OPERATING INSTRUCTIONS

SVF valves provide tight shut off when used under normal conditions and in accordance with SVF's published pressure/temperature chart. Consult with SVF for the proper seat material selection. Valve operation works by operating the valve handle 90° turn anti-clockwise

to open, and 90° turn clockwise to close. On manually operated valves the valve is open when the handle or stem flats are parallel with the pipeline and closed when the handle or stem flats are perpendicular to the pipeline. Valves above 2" have square a headed shaft with a groove that shows the ball position.

All standard valves are bidirectional and as such, can be installed for flow in either direction. Valves which are unidirectional will have a flow direction arrow welded to the body and separate assembly instructions. It is recommended to install flanged valves with the insert facing to the upstream direction.

If a shut-off valve is installed for end of line service, it must be ensured that it is closed with a blind end connection and the valve is secured against being opened unintentionally.

**WARNING:** Never look into the valve bore while the valve is in a flowline. Pressure and fluids could escape from the valve causing bodily injury.

A silicone-based lubricant is applied to assist valve break in. The lubricant, if unacceptable, may be removed by a solvent wash.

To prevent leakage malfunctions resulting from internal wear or seal degradation, the user must establish a preventive maintenance and inspection program. This program must include:

- a. Inspection of parts to detect loss of wall thickness which may result in decreased pressure capacity.
- b. Routine replacement of seals and inspection for proper operation.

Valve operating torques as published in the SVF literature are the normal expected maximum break-away torques. These torques have been confirmed by laboratory testing of each valve under controlled conditions. Highly viscous or abrasive media, frequency of operation and temperature fluctuations could cause an increase in valve torque.

## 5. INSTALLATION

The installation procedure for ball valves is critical to ensuring both long life and satisfactory performance. Valves stored on site awaiting installation should be kept in their original packing, in dry conditions, where damage will not occur. Before carrying out the installation, it is important to follow the basic procedures described below:

### 5.1 General

- 5.1.1 Carefully unpack the valve and check valve nameplate for identification of materials (see **Figure 1**).
- 5.1.2 Remove any special materials, which were used for packing.
- 5.1.3 Check the valve for any marks indication flow direction. Appropriate care must be taken, to install the valve for proper flow orientation.
- 5.1.4 Inspect the valve interior through the end ports to determine it is clean and free from foreign matter.
- 5.1.5 Cycle the valve and inspect any functionally significant features.
- 5.1.6 Read all the literature and note any special warning tags or plates attached to the valve.
- 5.1.7 Before installation of manually operated valves, check to insure the ball is in the fully open position in order to prevent possible damage to the ball and seats. Fail-to-close actuated valves should be operated to the open position for inspection. The valve performance depends on its original conditions.
- 5.1.8 Use the correct bolt material and size that suits the valve

flanges.

**5.1.9** Use the appropriate gasket material and structure for the application.

## 5.2 Flanged Valves

**5.2.1** Before installing the valves, make sure the flanges on the mating pipe are free from excessive grit, dirt or burrs.

**5.2.2** The mating flanges must be aligned and parallel with the correct distance to allow the valve face-to-face dimension and gaskets to fit between.

**5.2.3** Insert the valve between the mating flanges. If tilting or levering of the flanges is required, avoid harming the sealing surfaces of the flanges.

**5.2.4** Align the valve and mating flanges and insert at least 2 bolts at the lowest side of the flange to support the gaskets.

**5.2.5** Insert the gaskets between the flanges. Insert the remaining bolts.

**5.2.6** Before tightening the bolts, make sure the gaskets are aligned with the raised face of the mating flanges.

**5.2.7** Tighten the flange bolts according to the gasket manufacturer's recommended instructions or to the torque figures shown in **(table 2)** using the tightening patterns in **(figure 2)**.

**5.2.8** It is recommended to use ring spanners to tighten and support the bolts and nuts.

**5.2.9** Before flushing the line, be sure the valves are in the fully open position. Fail-to-close actuated valves should be operated to the open position for flushing.

**5.2.10** Before pressure testing the valves, bring the valves to the half-open position to ensure pressure reaches the stem seals and to avoid unnecessary loading of the seats. Fail-to-close actuated valves should be brought to the half-open position.

## 6. MAINTENANCE

SVF valves have a long and trouble free life, and maintenance is seldom required. When maintenance is necessary, valves can be refurbished on site.

To extend valve performance and reduce possible plant problems, the following procedures should be followed:

**6.1** If leakage at the stem area is noted, it is recommended to tighten the gland nut about 1/6-turn as a routine maintenance procedure. This will compensate for any wear or settling of the gland packing.

**6.2** **Caution:** Excessive tightening of the stem nut can result in accelerated seal wear and high valve operating torque.

**6.3** If the valve is removed from the line and disassembled, replacement of all seats and seals is recommended using the appropriate SVF Repair kit. Examine all metallic sealing surfaces such as ball and stem or the body and insert mating surfaces that contact the seats for wear, corrosion or damage.

**6.4** Only SVF's authorized spare parts should be used. Repair kits from SVF flanged reduce bore valves consist of the following:

2 x soft seat rings

1 x body seal

1 x stem thrust ring

2 or 3 x gland packing (depends on valve size or seal material)

**6.5** In addition to repair kits, other spare parts available from SVF are: valve balls, stems, glands, bolts, screws and nuts. Should additional parts be required, it is recommended that the complete valve be replaced.

**6.6** When ordering repair kits, please provide the valve size and full figure number code and series.

## 7. DISASSEMBLY

The following instructions are for disassembly of flanged valves sizes 1/2" to 2".

**7.1** Cycle the valve with the line pressure fully relieved before attempting to remove the valve from the pipeline, to insure pressure has also been discharged from the valve cavity.

**7.2** Loosen all flange bolts. Before removing the valve, allow the fluid to drain from the valve ports.

**7.3** Remove all but one flange bolt on either side of valve, so the valve body can swing away from its installed position and be brought out of the pipe line. Make sure there is no load on the flange before removing the remaining bolts and valve. If needed, use a lever to release the bolts.

**7.4** Clamp the valve in a vice or connect the valve back flange to a fixture to support it before removing the valve insert.

**7.5** Bring the valve to the closed position.

**7.6** Remove the valve insert using a hexagon shape key or a special tool. It may be necessary to use a pipe extension for the tool.

**7.7** Remove the seat and the body seal. Be careful not to damage the sealing surfaces.

**7.8** From the other valve end port tap the ball out using a wooden or plastic mallet. Support the ball to prevent it from falling out of the body. Set the ball aside in clean secure area for reuse.

**7.9** Remove the wrench nut, serrated washer, handle, locking clip, gland nut, disk springs and gland. Place all components removed, in clean secure area.

**7.10** Push the stem down into the body and remove it. Discard the stem thrust ring and packing, care taken not to scratch or nick the packing bore area of the body. Clean the stem and packing bore area.

**7.11** Using a tool with a hook, pull out the second seat from the valve cavity, taking care not to damage the sealing surfaces of the valve.

## 8. ASSEMBLY

The following instructions are for assembly of flanged valves sizes 1/2" to 2".

**8.1** Clean the valve entrance thread and the insert thread. Smear an anti-seize lubricant on the insert thread and screw it to the valve body until it reaches the thread end. Do not tighten hard. At this point the insert should be 0.2 mm above the valve raised face. Mark a straight line across the valve and insert to indicate the final screwed position for use later. Remove the insert from the valve body.

- 8.2 Insert one new seat ring into the valve cavity with its round profile facing up.
- 8.3 Lubricate the new stem thrust ring with appropriate lubricant (Molycote 33 - thin smear).
- 8.4 Place the stem thrust ring on the stem and insert the stem horizontally into the center body with the threaded side first and carefully guide it up through the stem bore.
- 8.5 Holding the stem up insert the new packing over the stem and into the stem bore. Place the gland and two disk springs onto the stem. The first spring concave side down and the second spring concave side up.
- 8.6 Thread the gland nut onto the stem. Tighten the gland nut to the torque figures (**table 1**).
- 8.7 Place the locking clip on the gland nut by adjusting the orientation of the nut (in the clockwise direction).
- 8.8 For manual valves, place the handle, serrated washer and thread the wrench nut on the stem. Holding the handle tighten the wrench nut tight. For actuated valves, place the serrated washer and thread the wrench nut on the stem. Holding the top of the stem tighten the wrench nut tight.
- 8.9 Bring the valve stem to the closed position and insert the ball in the valve cavity until the stem tang is engaged to the ball slot and the ball is nested in the seat.
- 8.10 Place the new body seal and seat ring (with its round profile facing the ball) into the valve body.
- 8.11 Screw back the insert using the proper tool and tighten to its preset mark as described in item 8.1 of this section. It is acceptable to be up to 20mm to the left of the body mark.
- 8.12 Refer to the Installation Instructions in section 5 of this manual to complete the valve assembly to the line.
- 8.13 Leave the valve in the open position for flushing the line.

## 9. DISASSEMBLY

The following instructions are for disassembly of flanged valves sizes 3" to 8".

- 9.1 Follow steps 7.1 to 7.5 from previous section.
- 9.2 Use a press or an opposing blind flange and press the valve insert into the body.
- 9.3 Loosen the valve insert retaining screws using a hexagon key and thread them out without removing them completely from their holes. Release the press or loosen the blind flange.
- 9.4 To assist removal of parts, tap on the ball from the other valve end port using a wooden or plastic mallet. Support the insert and the ball to prevent them from falling out of the body. Pull out the seat from the insert, taking care not to damage the sealing surfaces. Set the insert and the ball aside in clean secure area for reuse.
- 9.5 Remove the body seal. Be careful not to damage the sealing surfaces.
- 9.6 Pull out the second seat from the valve cavity, taking care not to damage the sealing surfaces of the valve.
- 9.7 Remove the wrench bolt, wrench pipe, wrench head, gland

nut, indicator stop plate and gland. Place all components removed, in clean secure area.

- 9.8 Push the stem down into the body and remove it. Discard the stem thrust ring and gland packing, care taken not to scratch or nick the packing bore area of the body. Clean the stem and packing bore area. There is no need to remove the stem location ring.

## 10. ASSEMBLY

The following instructions are for assembly of flanged valves sizes 3" to 4".

- 10.1 Insert one new seat ring into the valve cavity with its round profile facing up.
- 10.2 Lubricate the new stem thrust ring with appropriate lubricant (Molycote 33 - thin smear).
- 10.3 Place the stem thrust ring on the stem and insert the stem horizontally into the center body with the threaded side first and carefully guide it up through the stem bore.
- 10.4 Holding the stem up insert the new packing over the stem and into the stem bore. Place the gland and indicator stop plate onto the stem.
- 10.5 Thread the gland nut onto the stem. Tighten the gland nut to the torque figures (**table 1**).
- 10.6 Place the wrench head on the stem square so the pipe will be parallel to the groove marked on its head. Insert the pipe in the wrench head and screw the wrench bolt.
- 10.7 Actuated valves have a special stem assembly supplied with the mounting kits. Place two disk springs onto the gland. The first spring concave side down and the second spring concave side up. Insert the stem location ring and tab washer and fasten the no-slotted nut.
- 10.8 Bring the valve stem to the closed position and insert the ball in the valve cavity until the stem tang is engaged to the ball slot and the ball is nested in the seat.
- 10.9 Place the new body seal into the valve body.
- 10.10 Place the second seat ring with its round profile facing up into the valve insert.
- 10.11 Holding the insert and the seat together from the inside of the passage, place them into the valve body with the seat round profile facing the ball.
- 10.12 Press the insert with a press or blind flange into the valve body, making sure to keep the seat in place.
- 10.13 Screw back the insert retaining screws using the proper tool and tighten them all.
- 10.14 Refer to the Installation Instructions in **section 5** of this manual to complete the valve assembly to the line.
- 10.15 Leave the valve in the open position for flushing the line.

**FIGURE 1**  
**Valve Marking and Labeling**

All valves marking is on a nameplate which is spot welded to the valve body. Valves for the European market and above 1" carry the CE mark with the information required by the PED.

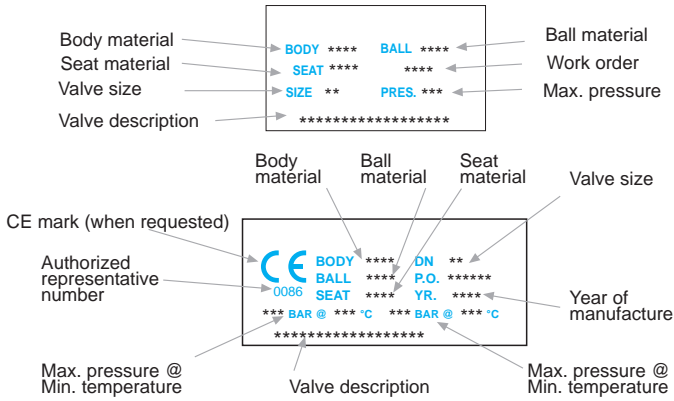

Valves required to comply to the ATEX directive have the Epsilon X distinctive community mark with the information required by the PED.

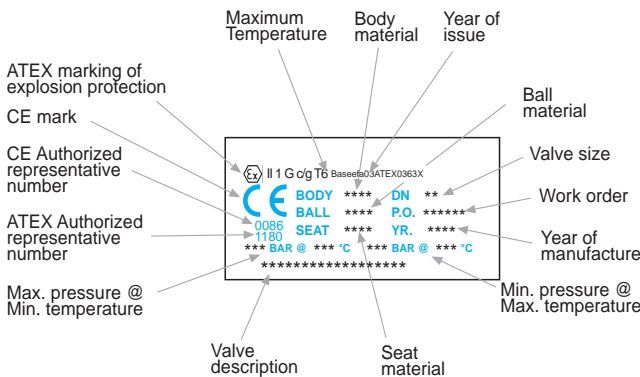

**TABLE 1**  
**Gland Nut Tightening Torque**

Valve Size (in)	Valve Size (DN)	Nut Thread	* PTFE Seals		** Graphite Seals	
			Nm	in.lb	Nm	in.lb
1/2"	15	3/8"-24 UNF	4.0	35	4 - 6	35 - 53
3/4"	20	3/8"-24 UNF	4.0	35	4 - 6	35 - 53
1"	25	7/16"-20 UNF	9.0	80	9 - 11	80 - 97
1 1/2"	40	9/16"-18 UNF	13.0	115	13 - 16	115 - 140
2"	50	9/16"-18 UNF	13.0	115	13 - 16	115 - 140
3"	80	1" - UNS	60.0	530	60 - 72	530 - 637
4"	100	1" - UNS	60.0	530	60 - 72	530 - 637
6"	150	1 1/2" - UNS	120.0	1060	120 - 145	1060-1280
8"	200	1 1/2" - UNS	120.0	1060	120 - 145	1060-1280

\* These torque figures are applicable on other stem seal materials such as glass filled PTFE, UHMWPE and TFM.

\*\* Graphite stem seals must be torqued to the higher torque figure in the table, then cycled 6-10 times and re-torqued to the lower torque figure.

**IMPORTANT:**

An excessively tightened gland nut can cause excessive packing wear and increase stem torque.

**TABLE 2**  
**Flange Bolt Tightening Torque**

The following table provides flange bolt torque values and are to be used as guidelines only and are not rigid limits.

The torque values will be determined by the gasket type and the material of the gasket, bolt, flange and lubricant used. It is the responsibility of the user to determine all these parameters and use the correct values.

Valve Size (in)	Valve Size (DN)	ANSI 150		ANSI 300	
		Nm	in.lb	Nm	in.lb
1/2"	15	80	710	80	710
3/4"	20	80	710	140	1,240
1"	25	80	710	140	1,240
1 1/2"	40	80	710	240	2,120
2"	50	140	1,240	140	1,240
3"	80	170	1,500	250	2,210
4"	100	170	1,500	250	2,210
6"	150	170	1,500	250	2,210
8"	200	170	1,500	420	3,720

**IMPORTANT:**

From the bolts point of view, the torque selected should be high enough to ensure adequate strain (stretch) in the bolt, but not so high as to cause the material to be taken beyond yield into the plastic response region.

If the initial bolt stress is too low the total amount of strain (stretch in the bolt) is low and under these circumstances any subsequent reduction in thickness of the gasket due to creep will quickly result in loss of bolt strain and subsequent leakage.

**FIGURE 2**  
**Flange Bolt Tightening Pattern**

When installing the valves in-line, follow the bolt tightening patterns shown below, using the recommended torque figures for safe operation.

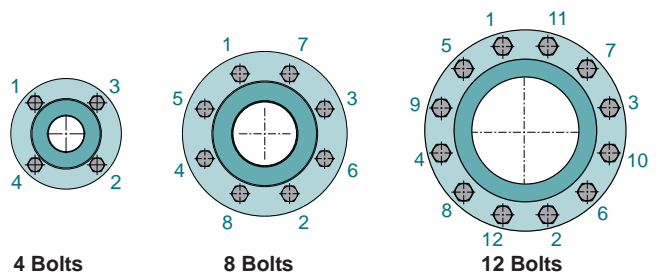

**31/41 SERIES FLANGED VALVE**

**SIZES: 1/2" - 2"**

**Material Specifications 1/2" - 2"**

ITEM	DESCRIPTION	MATERIAL	QTY.
1	BODY	STAINLESS ST. ASTM A351 CF8M CARBON ST. ASTM A216 WCB	1
2	INSERT	STAINLESS ST. ASTM A351 CF8M CARBON ST. ASTM A216 WCB	1
3	BALL	STAINLESS ST 316	1
4	STEM	STAINLESS ST 316, 17-4PH	1
*5	SEAT	PTFE, RPTFE, NRG and OTHERS	2
*6	BODY SEAL	PTFE, GRAPHITE and OTHERS	1
*7	STEM THRUST SEAL	PTFE, RPTFE, PEEK and OTHERS	1
8	STOP PIN	STAINLESS ST. AISI 304	1
*9	STEM PACKING	PTFE, GRAPHITE	2, 1
10	GLAND	STAINLESS ST. AISI 304	1
11	DISC SPRING	STAINLESS ST. 17-7PH	2
12	GLAND NUT	STAINLESS ST. AISI 316	1
13	TAB WASHER	STAINLESS ST. AISI 316	1
14	WRENCH	STAINLESS ST. AISI 430	1
15	SERRATED WASHER	STAINLESS ST. AISI 316	1
16	WRENCH NUT	STAINLESS ST. AISI 316	1
17	SLEEVE	VINYL PLASTISOL	1
18	TAG (NOT SHOWN)	STAINLESS ST. AISI 316	1

\* STANDARD ITEMS FOR REPAIR KITS

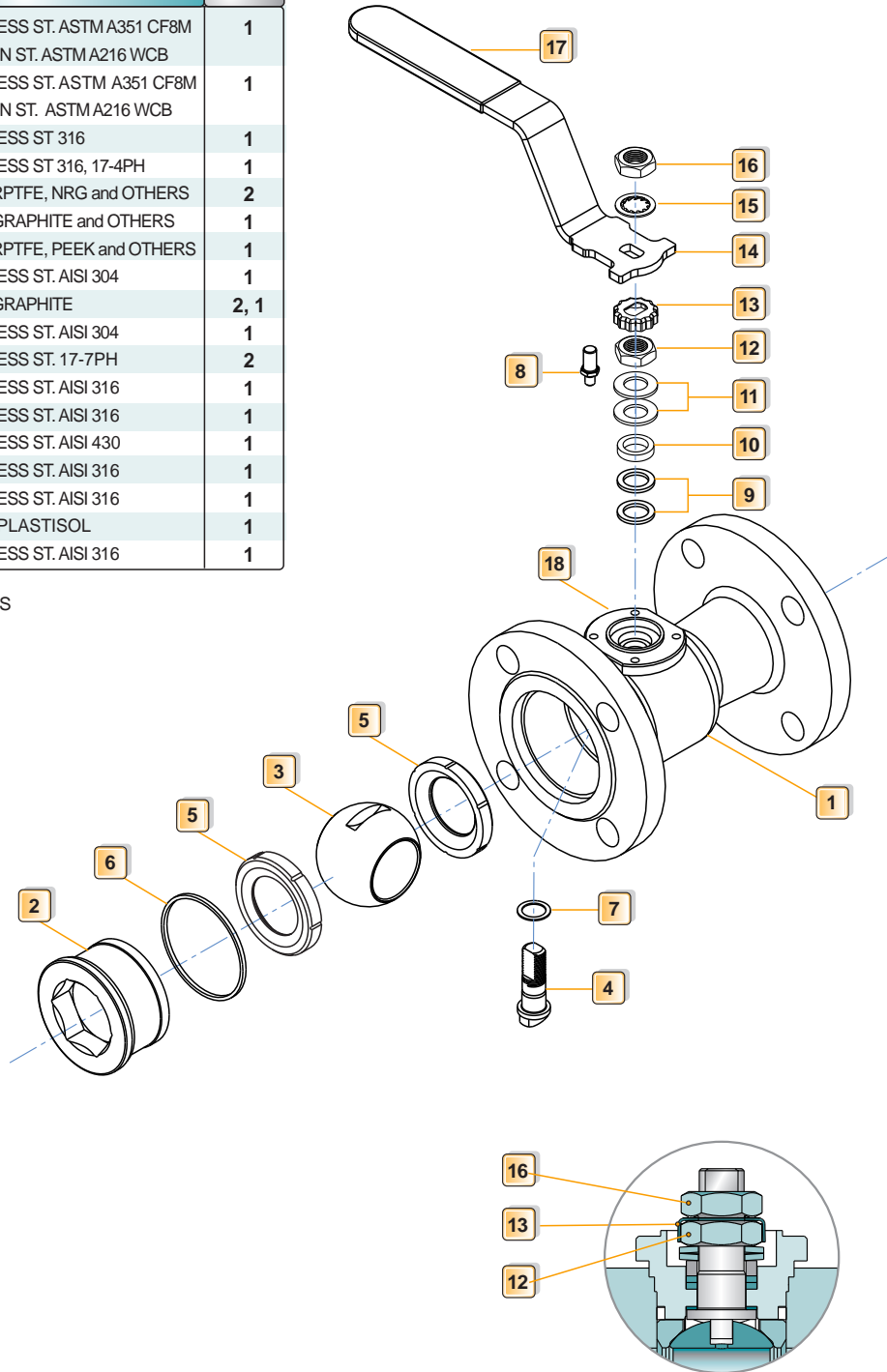

**Stem arrangement for actuated valves.**

Release the wrench nut **16** and serrated washer **15** and remove the wrench **14**. Refasten the nut **16** on the tab washer **13**. Valves 1/2" & 3/4" do require the wrench nut **16**.

SVF reserves the right to change design features without prior notice.

PEEK® is a trademark of VICTREX.  
VESPEL™ is a registered trademark of DuPont.

### 31/41 SERIES FLANGED VALVE

SIZES: 3" - 8"

#### Material Specifications 3" - 8"

ITEM	DESCRIPTION	MATERIAL	QTY.
1	BODY	STAINLESS ST. ASTM A351 CF8M CARBON ST. ASTM A216 WCB	1
2	INSERT	STAINLESS ST. ASTM A351 CF8M CARBON ST. ASTM A216 WCB	1
3	BALL	STAINLESS ST 316	1
4	STEM	STAINLESS ST 316, 17-4PH	1
*5	SEAT	PTFE, RPTFE, NRG, PEEK	2
*6	BODY SEAL	PTFE, GRAPHITE	1
*7	STEM THRUST SEAL	PTFE, RPTFE, PEEK	1
8	STOP PIN	STAINLESS ST. AISI 304	1
9	STEM LOCATION RING	STAINLESS ST. AISI 316	1
*10	GLAND PACKING	PTFE, GRAPHITE	3, 1
11	GLAND	STAINLESS ST. AISI 316	1
12	INDICATOR STOP PLATE	CARBON ST. ZINC PLATED	1
13	GLAND NUT	CARBON ST. ZINC PLATED	1
14	WRENCH HEAD	MALLEABLE IRON ZINC PLATED	1
15	WRENCH HANDLE	TUBE SCH. 40 ZINC PLATED	1
16	WRENCH BOLT	STAINLESS ST. AISI 304	1
17	RETAINING SCREW	STAINLESS ST. or CARBON ST.	4, 8
18	TAG (NOT SHOWN)	STAINLESS ST. AISI 316	1

\* STANDARD ITEMS FOR REPAIR KITS

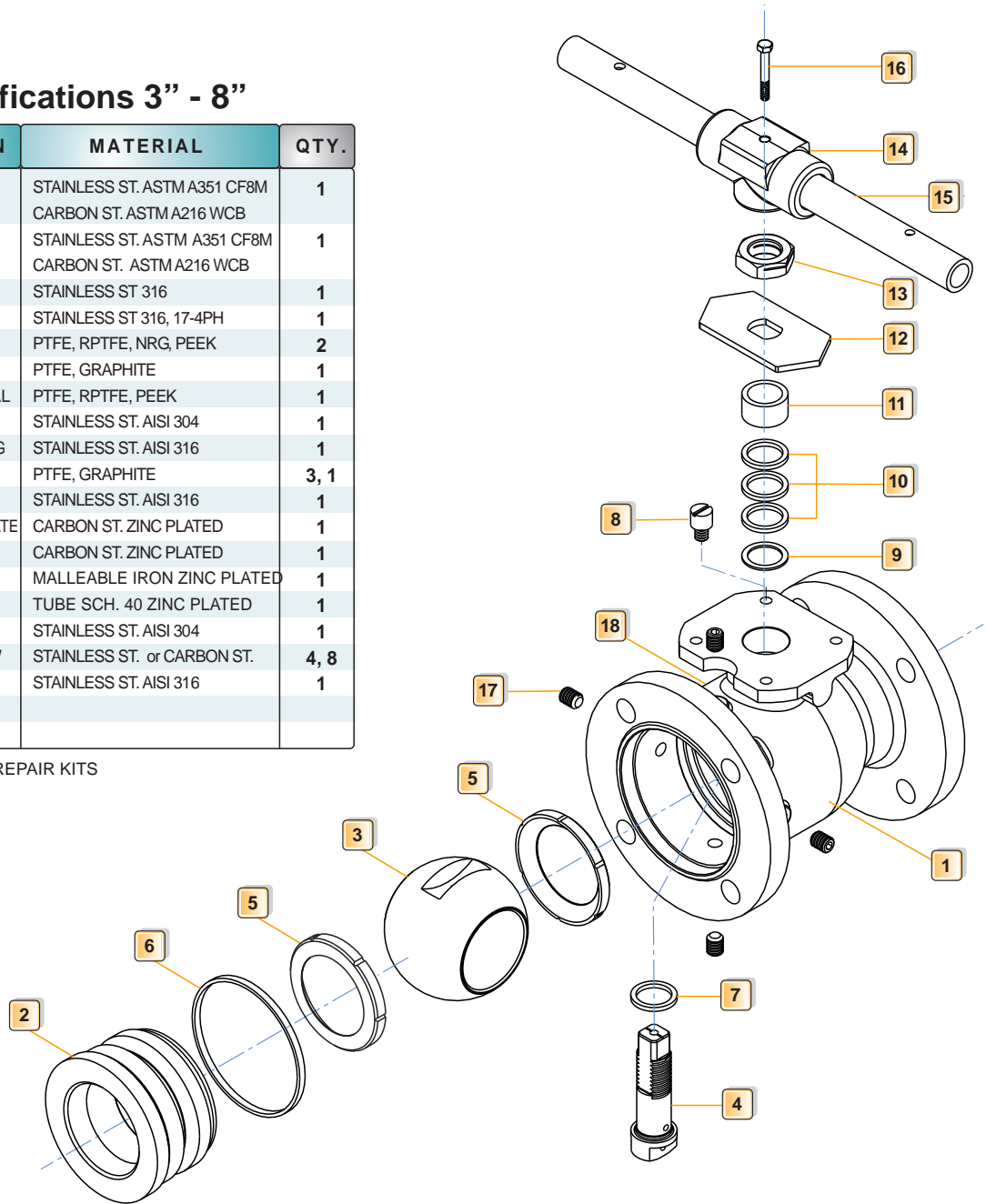

#### Graphite body seals assembly

In some cases the graphite body seal is supported by a metal ring and has an additional thin PTFE seal. Make sure to assemble them according to the illustration so the PTFE seal is positioned between the metal ring and the valve insert.

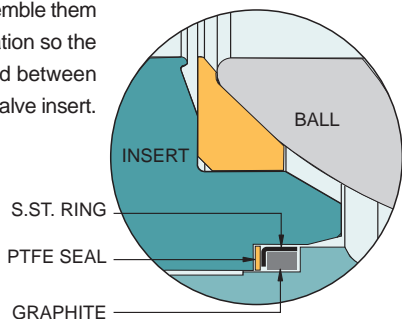

#### Stem arrangement for actuated valves.

Release the wrench bolt 16 and remove the wrench handle 15 the wrench head 14, the gland nut 13 and stop plate 12. Assemble the two disc springs 21, stem location ring 9, tab washer 22 and refasten the non-slotted gland nut 23.

