



"V" SERIES

VP, VE, VI, VX, VF POSITIONERS

Pneumatic and Electro-Pneumatic Positioners

MODULAR

Modularity is the cornerstone of the entire "V" Series line of Pneumatic and Electro-Pneumatic Positioners. Upgrading or modifying any unit is quick and hassle-free. Switch from pneumatic to electro-pneumatic with ease. Upgrade a Positioner in the field with Limit Switches and Position Transmitters easily. The "V" Series simplifies upgrades, minimizes inventory and eases service like no other line on the market.

EASY TO MOUNT

Adaptability is a key feature of the "V" Series. Regardless of actuator model or design, choosing the optional Universal Mounting Kit allows for customized adaptation to most current industry models, sizes and styles of quarter-turn actuators. The low profile design of the "V" Series Universal Mounting Kit ensures high performance adaptation to the accessory side of the actuator.

CORROSION RESISTANT

Corrosion resistance is unequalled in the "V" Series. The I/P Converter and Position Feedback Transmitter are epoxy sealed and the Proximity Switches are hermetically sealed for the ultimate in environmental protection. The PPA enclosure and internals exceed NEMA standards and are specifically designed for all routine and most highly corrosive applications. The PPA enclosure is inherently waterproof and carbon graphite filled to satisfy the toughest demands in both indoor and outdoor applications.

True Modularity • Universal Mounting • Field Upgradeable • Encapsulated Electronics • Corrosion-Resistant Housing • Hazardous Location Models

Components Count on trouble-free, economical operation from every SVF "V" Series Positioner.

Performance Truly modular and truly upgradeable in the field, the beauty of the "V" Series is *simplicity!*

Reliability Dust tight. Water tight. Vibration resistant. Corrosion resistant. NEMA-standard composite enclosures. Whatever the application, SVF "V" Series Positioners pass the test with flying colors.

Precision The SVF "V" Series affords precise, accurate mechanical calibration with Click-Lock™.

I/P Conversion Automatic compensation for supply pressure, atmospheric pressure & ambient temperature changes.

Safety The "V" Series Model VI incorporates an FM-, CSA- and Cenelec-approved converter that delivers safe, non-incendive service in both hazardous and general-purpose locations.

Specifications subject to change. Visit www.SVF.net for the latest updates. All Data Sheets posted on our website supersede all prior publications • [Document #DDS-VP • Model VP-VE-VI-VX-VF Positioner Data Sheet - 05/15/2011]

The SVF "V" Series Pneumatic & Electro-Pneumatic Positioners are designed and manufactured to offer years of trouble-free and economical operation. Every component has been field-tested and field-proven to exceed expectations of performance and reliability.

"V" SERIES DESIGN FEATURES

- ✓ Universal mounting flexibility
- ✓ Truly Modular/Totally field upgradeable
- ✓ Corrosion and Vibration Resistant/Epoxy Encapsulated Components
- ✓ Precise Click-Lock™ Calibration
- ✓ Stainless Steel Fasteners and port reinforcements
- ✓ Standard Flow or Maximum Flow Spool Valves available
- ✓ Mechanical and Proximity Switches available
- ✓ I/P Converter designed to provide flawless automatic compensation for Supply Pressure, Atmospheric Pressure, and Ambient Temperature changes
- ✓ Additional I/P Converters for the following Hazardous Location options:
 - Intrinsically Safe
 - NEMA 7 (applicable to the I/P metal housing only)†

†The Positioner housing is NEMA 4X only



"V" Series Positioner mounted on *aero2* actuator and SVF Series V8 V-Ball Valve.

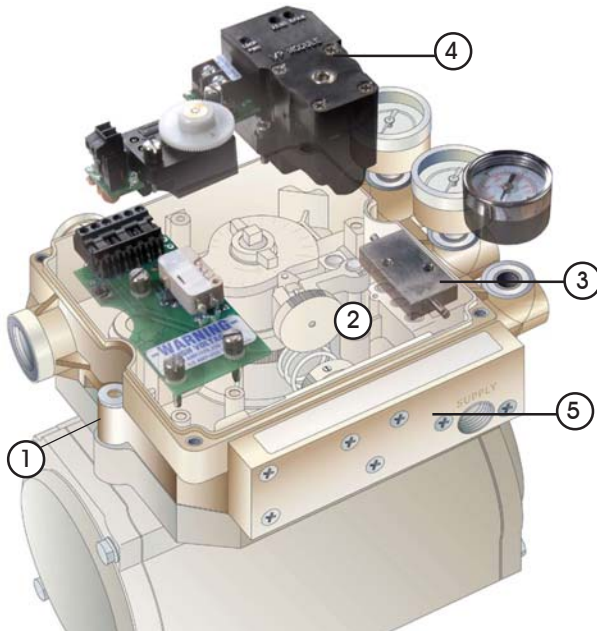

MATERIALS OF CONSTRUCTION

ITEM#	DESCRIPTION	MATERIALS
1	Enclosure	PPA Composite, 300 Series Stainless Port Rings, Cover and Mounting Bolts
2	Internals	PPA, PPS and PEEK Composites, 300 Series Stainless Steel, Nickel Plated Brass
3	Spool Valve	Carpenter 70 Grade Stainless Steel
4	I/P Converter	PPA Composite, Delrin®, TEFLON Coated Carbon Steel, Nickel Plated Carbon Steel, High Density Polyethylene,
5	Signal Diaphragm/O-Rings	Buna "N"

What do you need today?™

HIGH PURITY
CleanFLOW
www.CleanFLOW.net

PRO-SPEC
PROCESS SPECIFIC
WWW.PRO-SPEC.NET

QUALITY FLOWS
THROUGH US



DIMENSIONS Dimensions are in inches [Bracketed Dimensions are mm]

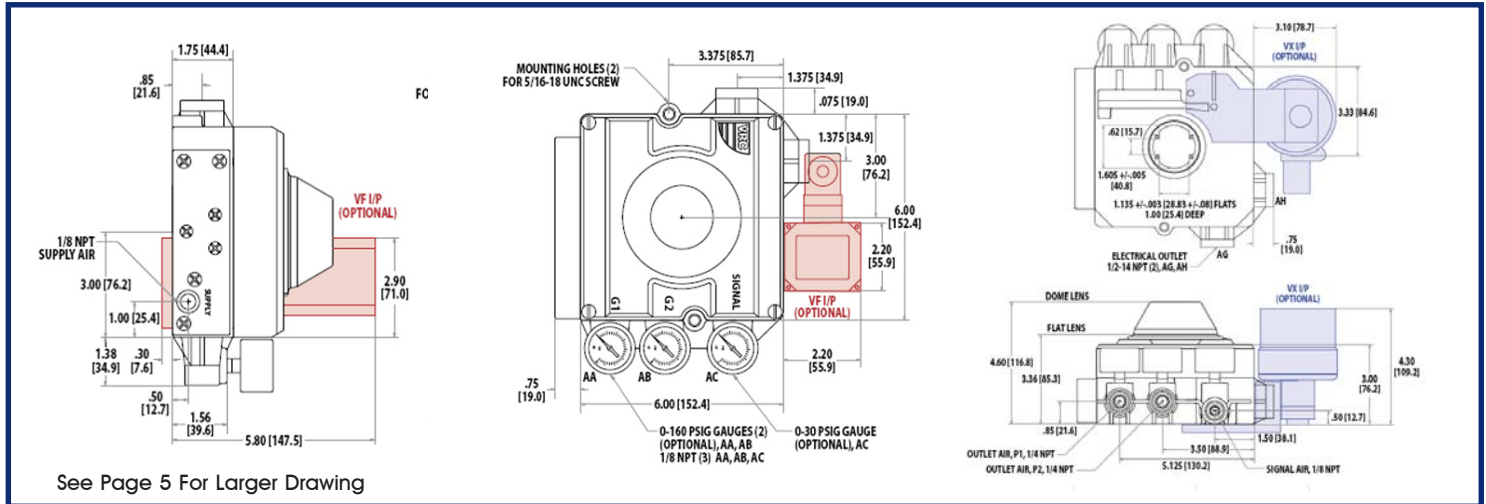

PERFORMANCE

PARAMETER	SPECIFICATION
Resolution	0.25% Maximum 0.10% Typical
Repeatability	99.75% Minimum 99.90% Typical
Hysteresis	0.50% Maximum 0.25% Typical
Linearity	+/- 1.0% Maximum
Gain @ 80 PSIG	250 Single-Acting 500 Double-Acting
Air Consumption @ 80 PSIG	0.25 SCFM Standard Flow Spool Valve 0.45 SCFM Maximum Flow Spool Valve
Temperature Range	-40 to 150° F (-40 to 65° C)

Standard Flat Top 90° Position Indicator



Optional Dome Top Position Indicator



MODELS (See Page 4 for Options, How To Order Guide and Hazardous Locations Information)

General Purpose



Fail-Freeze I/P
(Fail in Last Position)



Hazardous Locations
External I/P



General Purpose +
Hazardous Locations
(Intrinsically Safe
Non-Incendive)





DIMENSIONS Dimensions are in inches [Bracketed Dimensions are mm]

