



The SVF Series B41 Rev3 Flanged Ball Valves are high performance, full ported valves certified to API-607 fire safe design, ISO Top Works for direct mounting of actuator and a selection of seats and seals for a wide range of industrial applications.

### SERIES B41 REV3 DESIGN FEATURES

- ✓ Standard Fire Safe Certification to API 607, Anti-Static
- ✓ Standard NACE MR0175
- ✓ Built-In ISO 5211 direct mounting pad for easy automation
- ✓ Standard seat material is TFM1600™
- ✓ Optional SupraLon™ Seats for higher temperature, steam, and thermal fluid applications
- ✓ Latch lock handle fully compatible with OSHA clamp for Lock-Out/Tag-Out
- ✓ Live-loaded stem packing ensures seal-tight pressure containment even under thermal cycling



Contact SVF for Gear Operator information.

### MATERIALS OF CONSTRUCTION

ITEM	DESCRIPTION	MATERIALS SPECIFICATIONS (Additional options available)
1	Body	A351 CF8M A216 WCB
2	End Cap	A351 CF8M A216 WCB
3	Ball	A351 CF8M
4	Ball Seat	TFM1600™, SupraLon™
5	Body Bolt	A193 B8
6	Stem	SUS316
7	Anti-Static Device	SUS316
8	Thrust Washer	SupraLon™
9	O-Ring	VITON®
10	V-Ring Packing	GRAFOIL®, PTFE
11	Bushing	SUS304
12	Gland	SUS316
13	Belleville Washer	SUS301
14	Stem Nut	A194-8
15	Lock Tab	SUS304
16	Handle Gland	SUS304
17	Handle Nut	A194-8
18	Handle (1/2" ~ 2-1/2")	SUS304
19	Lock Device (1/2" ~ 2-1/2")	SUS304
20	Handle Sleeve (1/2" ~ 2-1/2")	VINYL PLASTIC
21	Body Gasket	316SS+GRAFOIL®, PTFE
22	Bolt Nut	A194-8
23	Stop Bolt	A193 B8
24	Handle Adapter (3" ~ 8")	A351 CF8
25	Set Screw (3" ~ 8")	A193 B8
26	Pipe Handle (3" ~ 8")	SUS304
27	Triangular Stopper (3" ~ 8")	SUS304
28	Pipe Handle Sleeve (3" ~ 8")	VINYL PLASTIC
29	Stop Nut	A194-8

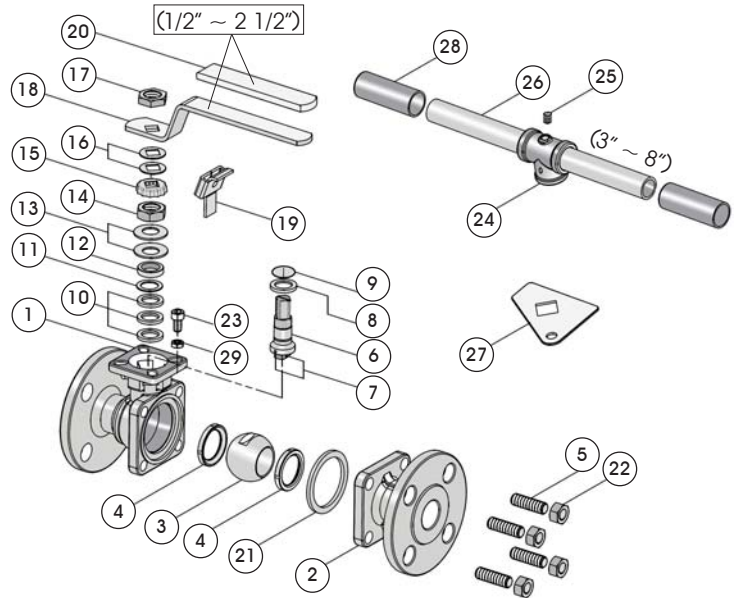

### SPECIFICATION STANDARDS OF COMPLIANCE

- Design - ASME B16.34, NACE MR0175
- Face to Face: ASME B16.10
- End Flange: ASME B16.5
- Wall Thickness: ASME B16.34
- Inspection & Testing: API 598, and optional API 6D
- Fire Safe: API 607, ISO 10497

What do you need today?™



Subject to revisions. Please visit [www.SVF.net](http://www.SVF.net) for the latest updates on this Data Sheet. All Data Sheets posted on our website supersede all prior publications • [Document #DDS-B41r3-04/26/2010 • Series B41 Rev3 Data Sheet - 04/26/2010]

[www.SVF.net](http://www.SVF.net)

SVF Flow Controls, Inc. • 13560 Larwin Circle • Santa Fe Springs, CA 90670 • Tel: 1.800.783.7836 • FAX: 562.802.3114  
Sales@SVF.net • Visit our website: [www.SVF.net](http://www.SVF.net) • © SVF Flow Controls, Inc. • Specifications subject to change without notice

**Flanged Ball Valve, ANSI Class 150, Full Port, Sizes 1/2" ~ 8"**

**B41  
Rev3**

**DIMENSIONS, WEIGHT, C<sub>v</sub>, TORQUE**

**Torque\* Tables**

Size	A		B		D		L		Weight.		C <sub>v</sub>	TFM1600™		SupraLon™	
	in.	mm	in.	mm	in.	mm	in.	mm	lbs	kg		in-lb <sub>f</sub>	Nm	in-lb <sub>f</sub>	Nm
1/2"	4.25	108	0.59	15	5.70	145	3.07	78	4	1.8	25	72	8	91	10
3/4"	4.62	117	0.79	20	5.70	145	3.31	84	5	2.2	45	81	9	98	11
1"	5.00	127	0.98	25	6.90	175	3.52	89	6	2.7	85	130	15	172	19
1-1/2"	6.50	165	1.50	38	7.50	190	4.21	107	13	5.9	200	299	34	368	42
2"	7.00	178	1.97	50	7.50	190	4.41	112	24	10.9	320	371	42	460	52
2-1/2"	7.50	190	2.48	63	10.45	265	5.91	150	30	13.6	450	598	68	728	82
3"	8.00	203	2.99	76	11.80	300	6.30	160	38	17.4	600	988	112	1209	137
4"	9.00	229	3.94	100	15.75	400	8.03	204	69	31.5	1100	1508	171	1846	209
6"	15.50	394	5.91	150	31.50	800	10.85	275	161	73.6	2600	4160	470	5200	588
8"	18.00	457	7.87	200	31.50	800	11.00	279	277	126.6	4200	6500	735	8060	911

**B41 REV3 - PRESSURE/TEMPERATURE CHART**

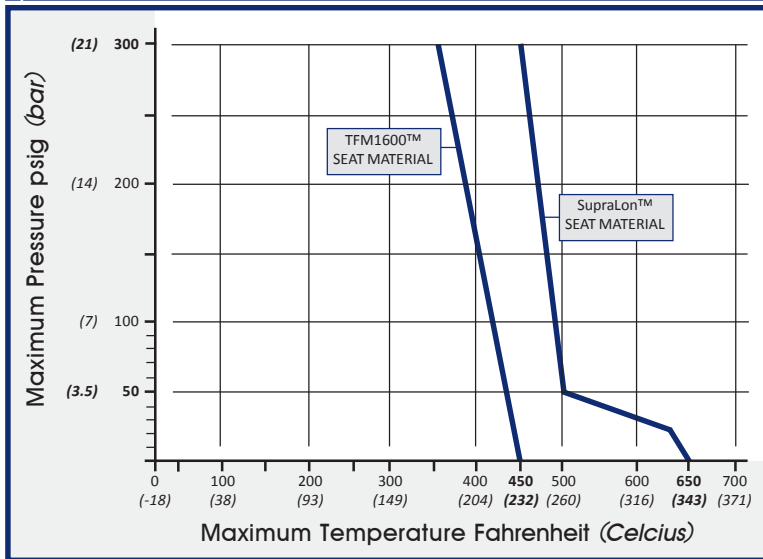

\* At full differential pressure

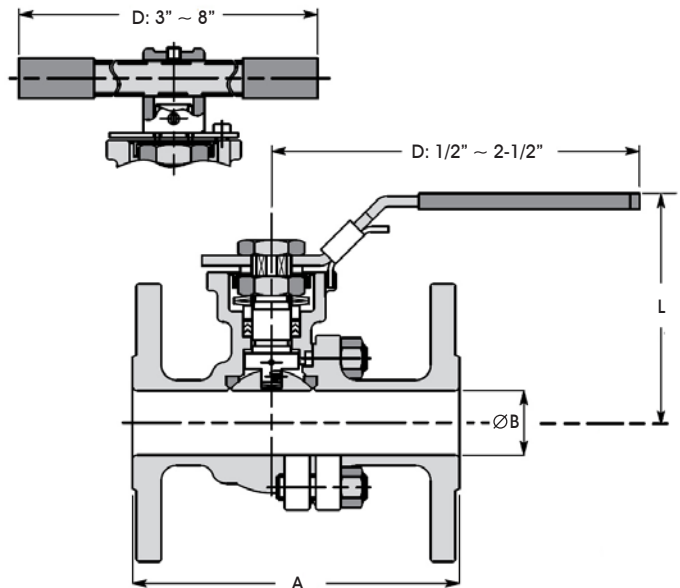

**HOW TO ORDER SERIES B41 REV3 BALL VALVES**

SERIES	BODY, BALL & STEM	SEAT	BODY SEAL	REV DESIGNATION	MOUNT	SIZE
B41 = Full Port ANSI Class 150 Flanged	<b>4</b> = Carbon Steel Body A216 WCB with 316 SS Ball A351 CF8M & 316 SS Stem SUS 316  <b>6</b> = 316 Stainless Steel Body A351 CF8M with 316 SS Ball A351 CF8M & 316 SS Stem SUS 316	<b>A</b> = TFM1600™ <b>S</b> = SupraLon™	<b>G</b> = GRAFOIL® <b>T</b> = PTFE	<b>R3</b> = Rev3	<b>P</b> = Direct Mount	<b>05</b> = 1/2" <b>07</b> = 3/4" <b>10</b> = 1" <b>15</b> = 1-1/2" <b>20</b> = 2" <b>25</b> = 2-1/2" <b>30</b> = 3" <b>40</b> = 4" <b>60</b> = 6" <b>80</b> = 8"
<div style="border: 1px solid red; padding: 5px; display: inline-block;">                     *NOTE: Valves with PTFE Body Seals &amp; Stem Seals are not fire safe                 </div>						
<b>Order Example: (B416AGR3P05)</b>						
<b>Example Description: Full Port, 316 Stainless Steel Body, Ball &amp; Stem, TFM1600™ Seat, GRAFOIL® Body Seal, Rev3, Direct Mount, 1/2" Size</b>						
<b>B41</b>	<b>6</b>	<b>A</b>	<b>G</b>	<b>R3</b>	<b>P</b>	<b>05</b>