

IOM



"V" Series Positioners INSTALLATION, CALIBRATION & MAINTENANCE MANUAL

OCTOBER, 2011

PRINCIPLE OF OPERATION - PNEUMATIC SECTION

The SVF "V" Series Positioner is a force balance device. There are two (2) forces that oppose each other within the Positioner.

Reference Figure 1.

Force 1 is created by the signal pressure (3~15 PSI) being applied to the flexile SIGNAL DIAPHRAGM. Force increases as pressure is increased.

Force 2 is created by the rotation and cam rise of the FEEDBACK CAM. Force is increased as the CAM rotates from 0 to 90 degrees.

The two (2) opposing forces meet at the BALANCE BEAM which has the SPOOL VALVE attached at one end.

When the two (2) forces are not balanced, for example: an increase in signal pressure from 3 PSI to 15 PSI, the BALANCE BEAM is deflected causing the SPOOL VALVE to flow air to the actuator and rotation of the FEEDBACK CAM occurs until Force 2 equals Force 1. When this happens, the BALANCE BEAM and SPOOL VALVE return to a null position (SPOOL VALVE off) and actuator rotation stops.

FIGURE 1

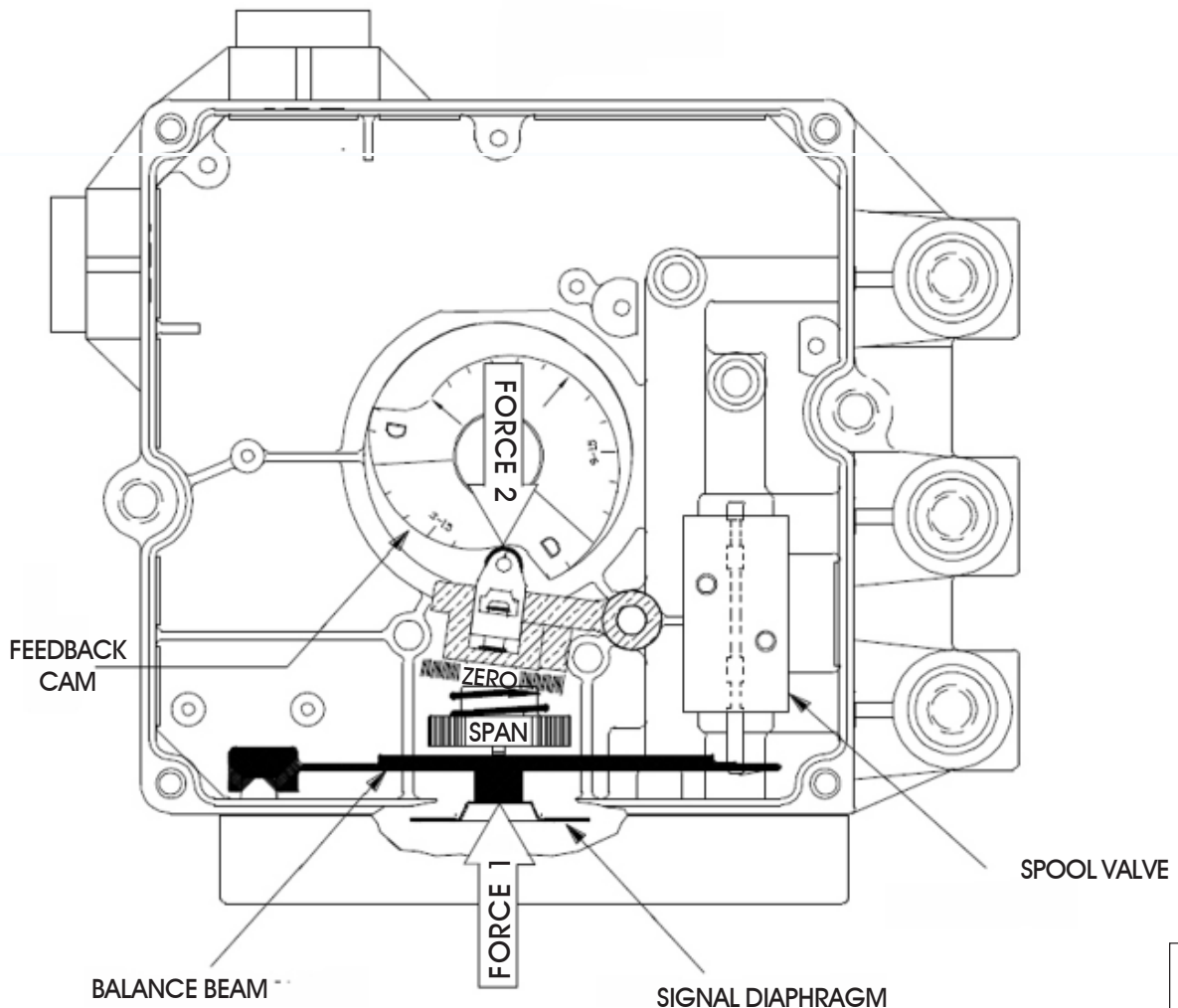

2

PRINCIPLE OF OPERATION - VK02 I/PMODULE

MODULE FUNCTION:

The VK02 I/P Module uses the latest in miniaturized electronics and pressure sensor technology to convert a 4-20mA electrical input signal into a 3~15 PSI pressure output signal.

The VK02 I/P Module is used in the Model VE Positioner and can be installed in a Model VP Positioner to change it to a VE Model. The VK02 I/P Module is designed for all general purpose location applications.

OPERATION:

Supply air is ported to the I/P MODULE through an internal Positioner passage. It is then filtered and regulated down to 25 PSI.

The regulated air is ported internally in the Module to a COIL/NOZZLE and allowed to bleed off in a controlled manner to develop the 3~15 PSI signal pressure.

A flexible teflon coated steel DIAPHRAGM is positioned over the nozzle and is magnetically moved closer or further away from the nozzle to increase or decrease the 3~15 PSI signal pressure.

Control for the 3~15 PSI signal pressure is achieved by electronically comparing the 4-20mA input signal with the 3~15 PSI pressure sensor signal.

When a change occurs on the 4-20mA input signal, the electronics cause a change in current flow to the COIL/NOZZLE ASSEMBLY and thus a change in the magnetic field strength. This then causes the DIAPHRAGM to change position and signal pressure is changed to correspond to the new 4-20mA input signal.

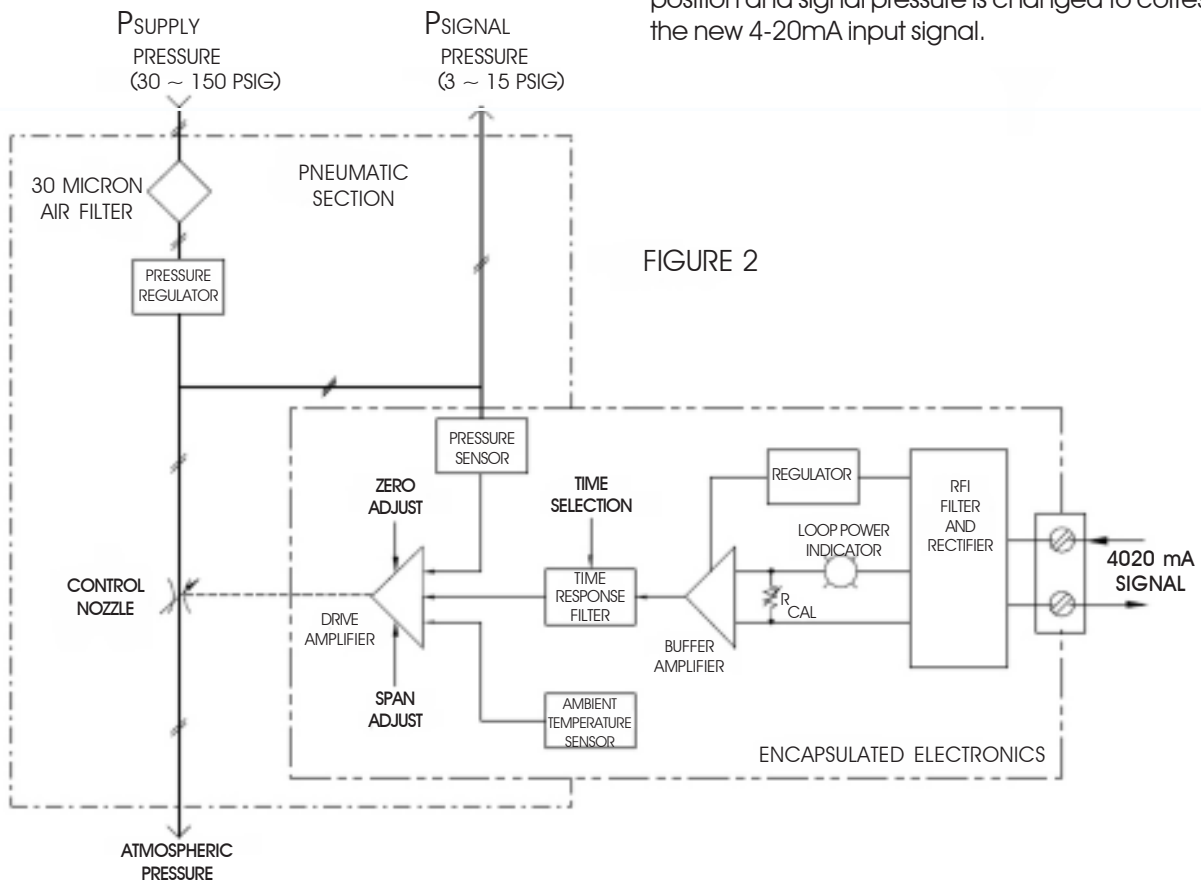

FIGURE 2

SIGNAL CURRENT TO SIGNAL PRESSURE
VK02 I/P CONVERSION MODULE



TECHNICAL DATA

POSITIONER SPECIFICATIONS

MODEL VP, VE, & VI

Electrical Input Models VE & VI	4-20 milliamps 40 Vdc Maximum .025 Amp Maximum
Resolution	.10% of span Typical .25% of span Maximum
Repeatability	99.90% of span Typical 99.75% of span Maximum
Hysteresis	.25% of span Typical .50% of span Maximum
Linearity	+/-1.0% of span Maximum
Gain	250 PSIG/PSIG Single Acting 500 PSIG/PSIG Double Acting
Model VP Std Input Ranges	3-15 PSIG Full Range 3-9 & 9-15 Split Range
Model VE Input Ranges	4-20 & 4-12/12-20 MA Electronic Split Range
Model VE Speed Control	APPROX: 5, 20, & 40 Seconds Jumper Selected
VE Voltage Required	12.5 Vdc Min.(equivalent 600 ohm)
VI Voltage Required	4.0 Vdc Min. (170 ohm load)
Stroke Range	0-90 & 0-180 Degrees
Supply Range	30 to 150 PSIG
Air Delivery	10 SCFM @ 80PSIG STD 15 SCFM @ 80PSIG MAX-FLOW
Air Consumption	0.25 SCFM @ 80PSI 0.45 SCFM @ 80PSI MAX-FLOW
Operating Temp.	-40 to +150 F -40 to +65 C
Temp. Effect	.02%/deg F (.04%/deg C)
Vibration Effect SAMA FMC 31.1-80	Less than 2% error 0-120 HZ 2G Acceleration
Pneumatic Connections	1/8 NPT Gauge Ports 1/4 NPT Supply Air Port 1/4 NPT Outlet Ports
Enclosure Classification	Designed to NEMA 4X Watertight, Dusttight & Corrosion Resistant
Enclosure Weight	Approximately 2 LBS

HAZARDOUS LOCATIONS APPROVALS

The integral I/P converter for the Model VI Positioner has the following Hazardous Location Approvals:

I/P Converter P.N. VK12, Type 22/06-65

Factory Mutual approved for:

Intrinsically Safe:

Class I, Division 1 Groups A,B,C,D

Non-Incendive / Division 2:

Class I, Division 2 Groups A,B,C,D

CSA approved for:

Intrinsically Safe:

Class I, Division 1 & 2, Groups A,B,C,D

For applications in Hazardous Locations reference control Documents No. 900842/900843, available by calling VRC at 513-677-8724 / fax 513-677-8731.

OPTIONS

S1-Mechanical Switches

Contact Form	(2) SPDT Switches
Ratings	10 Amp 125/250 Vac 1/2 Amp 250 Vdc
Operating Temp.	-40 to +185 F
Approvals	UL Recognized/CSA Certified

S2-Proximity Switches

Contact Form	(2) SPST Switches
Contact Rating	1 Amp, 120 Vac/200 Vdc 50 Watts Maximum
Operating Temp.	-14 to +150 F
Approvals	UL Recognized

T1- 4-20 MA Transmitter

Electrical Input	12 Vdc to 40 Vdc Maximum
Linearity	+/- 1% Maximum
Sensor Hysteresis	0.1 Degree or less
Operating Temp.	-40 to +150 F

MATERIALS OF CONSTRUCTION

Enclosure	PPA Composite, 300 Series Stainless Steel Rings, Cover & Mtg. Bolts
Indicator Lens	GE LEXAN
Internals	PPA, PPS, & PEEK 300 Series Stainless Steel Nickel Plated Brass
Spool Valve	300 Series Stainless Steel
Signal Diaphragm & O-rings	Buna-N
I/P Module (VK02)	PPS Composite 300 Series Stainless Steel Teflon Coated Carbon Steel Nickel Plated Brass & Steel High Density Polyethylene, & Delrin

POSITIONER INSTALLATION PROCEDURE

INTRODUCTION

The Positioner controls the position of a rotary or linear pneumatic actuator and its final control element by modulating the flow of supply air to the actuator in response to a control signal. There are (3) base models available:

- Model VP – pneumatic positioner
- Model VE – electro-pneumatic positioner
- Model VI – electro-pneumatic (for general purpose and Hazardous Locations)

MOUNTING PROCEDURE

The Positioner can be installed on Single or Double Acting rotary or linear actuators. The procedure is typical and assumes that the optional Universal Mounting Kit is used to mount the positioner to a rotary actuator.

1. Move the actuator to its start position
2. Secure the Universal Bracket to the actuator
3. Mount the Adapter to the actuator shaft

WARNING: The Adapter must be bolted to the actuator shaft to assure a reliable connection between the Positioner and actuator.

CAUTION: The Adapter (coupler) also may need to be machined to the proper length so that the Positioner bottoms out on the Bracket before the Adapter bottoms out inside the Positioner female shaft.

4. Align the female shaft of the Positioner with the Adapter and slide the Positioner down the actuator shaft until the Positioner is flush with the Bracket

CAUTION: An interference fit between the Adapter and Positioner shaft greater than 0.001 inch significantly increases the Positioner shaft torque and can damage the Positioner.

5. Cycle the Positioner and then place it in a mid-travel position. Use the Positioner mounting bolts to secure the unit to the Bracket.

PNEUMATIC CONNECTIONS

All air ports require user supplied NPT fittings. Unused ports require NPT pipe plugs. Scale free piping should be blown out before installation to prevent dirt and debris from entering the Positioner. Use accepted practice when installing the piping. Install shutoff valves, drains, and seals as required. The piping should slope upward toward the unit to reduce condensation from entering the Positioner. Use flexible connections for supply air and signal air connections.

Use pipe sealant on all air fittings. TEFLON sealant is recommended. Do not use tape.

CAUTION: Maximum torque for the 1/4 and 1/8 NPT ports is 12 and 6 ft. lbs. respectively.

The following piping connection procedure assumes the Positioner is properly mounted to the actuator and the actuator is in its start position.

1. Connect outlet ports P1 and P2 to the actuator using 1/4 inch NPT fittings. P1 and P2 are related to gauge ports G1 and G2 respectively.

P2 is always connected to the actuator port used to move the actuator away from its start position.

P1 is connected to the remaining actuator port for Double Acting actuators and Single Acting actuators with air assist. Otherwise **P1** is plugged.

2. Connect supply air to the Positioner SUPPLY port using a 1/4 NPT fitting.

3. Model VE & VI Positioners require the SIGNAL port to be plugged and are shipped from the factory with the plug installed. On Model VP Positioners connect the signal pressure to the SIGNAL port using a 1/8 NPT fitting.

NOTE: See I/P section for wiring instructions

SUPPLY AIR REQUIREMENTS

Supply air is required to be clean, dry, and oil free instrument quality air as defined in the ISA-S7.3 specification. Regulated air is not required but a supply air filter should be installed.

WARNING: Maximum pressure to be applied to the Positioner is 150 PSIG.

FEEDBACK CAM

With the Positioner mounted and the actuator at its start position the CAM FOLLOWER and bearing should be at the 0 degree point on the FEEDBACK CAM. Direct or Reverse Acting is accomplished by selecting the D or R side of the FEEDBACK CAM.

POSITIONER VENT

The Positioner exhausts air through a one way duckbill valve that is integral to the Positioner housing. In applications such as natural gas where the supply gas medium is to be recovered, the vent can be blocked using a cap plug. (VRC part number V00026).

WARNING!

IF THE CAP PLUG IS INSTALLED IN THE POSITIONER BREATHER VENT THE POSITIONER MUST BE EXHAUSTED THROUGH THE 1/2 NPT CONDUITS. FAILURE TO DO SO CAN RESULT IN BODILY INJURY DUE TO A BUILD UP OF INTERNAL PRESSURE, AND SUBSEQUENT RUPTURE OF THE POSITIONER HOUSING AND COVER!

SPECIAL INSTRUCTIONS FOR MODEL VI POSITIONER

The Model VI Positioner is designed for both General Purpose and Hazardous Locations as defined by the National Electrical Code (NEC). The Model VI has an integral I/P converter P.N. VK12 (type 22/06-85) that is FM & CSA approved as Intrinsically Safe and Non-Incendive for use in Hazardous Locations.

For applications in Hazardous Locations reference control Documents No. 900B42/900B43, available by calling VRC at 513-677-8724 / fax 513-677-8731.



CALIBRATION PROCEDURE - PNEUMATIC SECTION

NOTE: The VRC Positioner is calibrated at the factory for 0-90 degree rotation. Small adjustments may be needed due to mounting or differences in actuator rotation.

PRIOR TO CALIBRATING:

NOTE: REF. PAGE 6A FOR DRAWINGS

1. Tools required:

- Regular screwdriver (for removing HSG cover)
- For VE models: 4-20MA calibrator
- For VP models: 3-15 psi signal source

2. This procedure assumes the positioner is correctly mounted to an actuator and supply pressure is on.

3. For VE models, verify the I/P module is calibrated by referring to page 7 of these instructions.

4. For CLOCKWISE and COUNTERCLOCKWISE orientation, the front of the positioner is where the supply air port is located. Ref. figure 3.

5. **DIRECT** and **REVERSE ACTING**. Determine which positioner response you require:

DIRECT ACTING—is when the actuator is required to rotate Counterclockwise with increasing control signal.

REVERSE ACTING—is when the actuator is required to rotate Clockwise with increasing control signal.

After determining your requirement, verify the positioner feedback cam is installed correctly for your application. A "D" is molded on one side of the cam and on the opposite side an "R" is molded.

- For **DIRECT ACTING** the "D" side should be facing up.
- For **REVERSE ACTING** the "R" side should be facing up.

CALIBRATION PROCEDURE

ZERO ADJUSTMENT

NOTE: ZERO is defined as the START point of actuator rotation.

1. With 3 psi signal pressure applied, verify the actuator is at it's start point by manually deflecting the Balance Beam toward the front of the positioner housing while observing the Feedback Cam and Bearing Holder arrow (ref. figure 3A). The arrow should be pointing at the "0" on the Feedback Cam. If not, turn off supply air and reposition the Cam by removing the Wing Nut and unsplining the Cam. Reposition the Cam as required. Reinstall Wing Nut and turn supply air on.

2. Apply 3 psi signal pressure.

3. Rotate the ZERO Thumbwheel as required

- Clockwise rotation moves the Zero point upscale on the Cam (toward 90 degrees)
- Counterclockwise rotation moves the Zero point down scale on the Cam (toward 0 degrees)

NOTE: The Zero Thumbwheel is designed to give a feel for the amount of adjustment being made. Each click of the Thumbwheel is a .5 degree adjustment change.

CAUTION: Do not force the rotation of the Zero Thumbwheel, the Thumbwheel will rotate freely throughout it's adjustment range and forcing the rotation could damage the adjuster.

4. Zero is adjusted properly when increasing signal pressure from 3 psi to 3.5 psi causes the actuator to rotate away from it's start position (away from 0). Repeat step 3 if required.

SPAN ADJUSTMENT

NOTE: SPAN is defined as the full travel position of the actuator.

1. Apply 15 psi signal pressure to the positioner.

2. Determine if more or less actuator rotation is required.

NOTE: A quick check to verify if the actuator is against the actuator stops is to manually deflect the Balance Beam away from the front of the positioner. If the actuator continues to rotate when the Balance Beam is deflected, an increase in Span adjustment is required.

3. Rotate the SPAN Adjuster as required.

- Clockwise rotation of the adjuster decreases SPAN.
- Counterclockwise rotation of the adjuster increases SPAN.

NOTE: The Span Adjuster is designed to give a feel for the amount of adjustment being made. Each click of the adjuster is approximately 1 degree of change at the 90 degree setting.

4. SPAN is adjusted properly when decreasing signal pressure from 15 psi to 14.5 psi causes the actuator to move away from the actuator stops (away from 90 deg.). Repeat step 3 if required.

5. Recheck Zero adjustment.

CALIBRATION PROCEDURE - PNEUMATIC SECTION

NOTE: Figure 3A shows the correct relationship for the CAM and BEARING HOLDER for a DIRECT ACTING application when the actuator is at it's start point of rotation (3 PSI applied).

FIGURE 3A

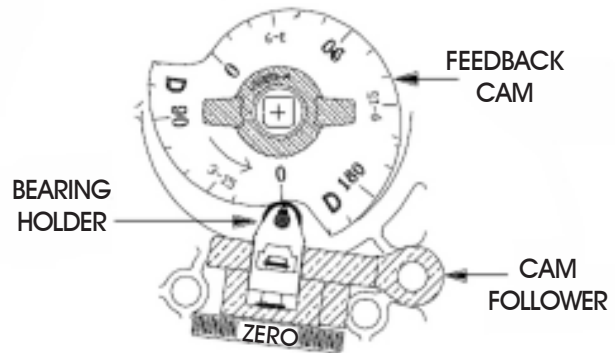
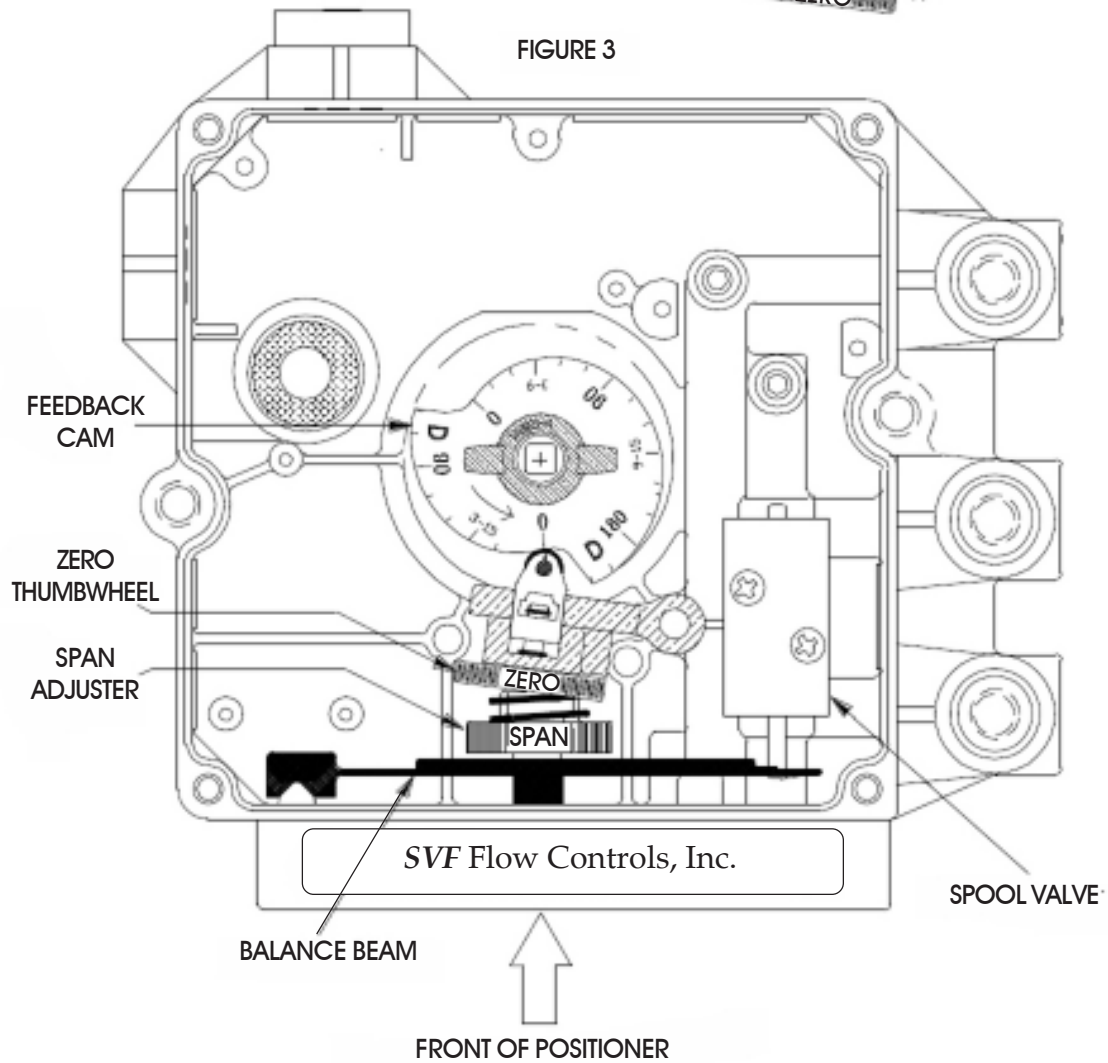

FIGURE 3



CALIBRATION PROCEDURE - VK02 I/P MODULE

CALIBRATION PROCEDURE (POSITIONER MODEL VE)

The VK02 I/P Module comes from the factory pre-tested and full calibrated and should not need recalibration on new installations. If the unit appears to need calibration, check all pipe fittings and connections for air leaks prior to performing the calibration procedure.

NOTE: To calibrate the I/P MODULE, the following items are required:

- a. 0~30 PSI pressure gauge in SIGNAL PORT
- b. 4-20mA calibrator (min. 1.2 volt output)
- c. Small slotted screwdriver
- d. 3/16" allen wrench

Reference FIGURE 4: BIAS PRESUURE ADJUSTMENT

This adjustment ensures a proper mechanical relationship between the CONTROL NOZZLE and the teflon coated DIAPHRAGM.

1. With supply pressure applied and NO electrical signal applied, check the SIGNAL PRESSURE GAUGE. The gauge should read 2.5 PSI to 3.0 PSI.

2. If required, using the allen wrench, adjust the BIAS PRES-SURE SCREW to obtain 2.5 to 3.0 PSI - clockwise decreases pressure, counterclockwise increases pressure. Typically, only small adjustments are required.

NOTE: If the pressure does not adjust or there is no pressure showing on the SIGNAL PRESSURE GAUGE, there may be an air leak. Check to ensure that the SIGNAL PORT has been plugged and that all O-Rings are installed. Also, check for any leakage at the gauge.

CAUTION!! CONTINUING TO ADJUST THE BIAS PRESSURE SCREW THE THESE CONDITIONS CAN DAMAGE THE MOD-ULE!

ZERO/SPAN ADJUSTMENT:

1. With the supply pressure still on, apply 4 mA to the I/P Module, adjsut the ZERO POT for 3 PSI.

2. Apply 20 mA, adjust the SPAN POT for 15 PSI.

3. ZERO and SPAN interact - repeat the above steps 1 and 2 and readust as required.

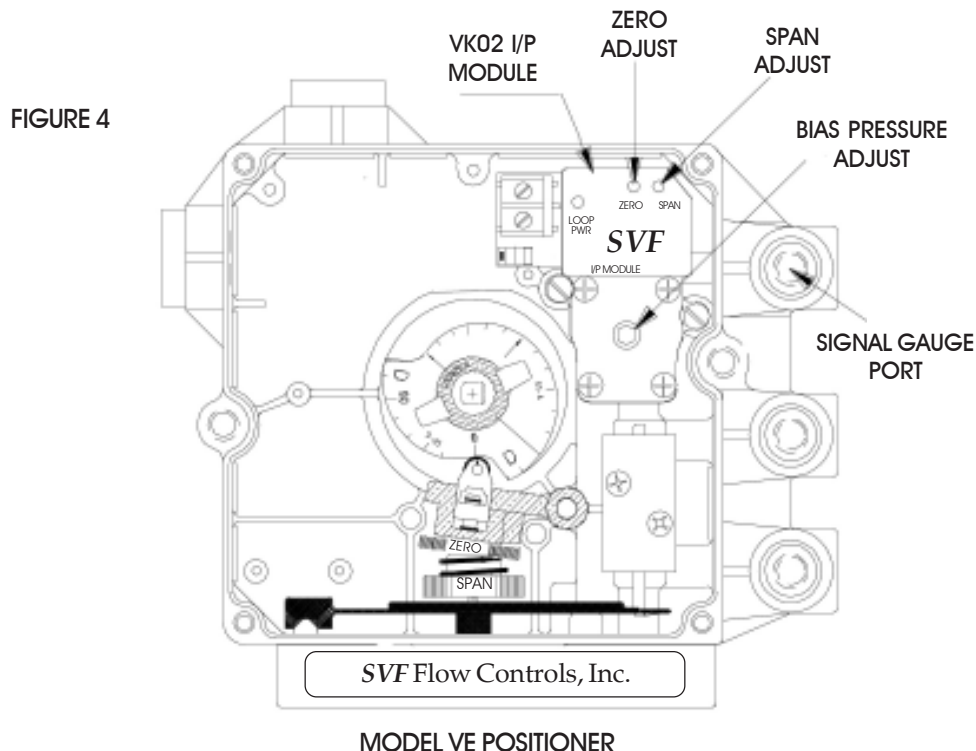

DIMENSIONAL DRAWING

DIMENSIONS are in inches [Bracketed Dimensions are mm]

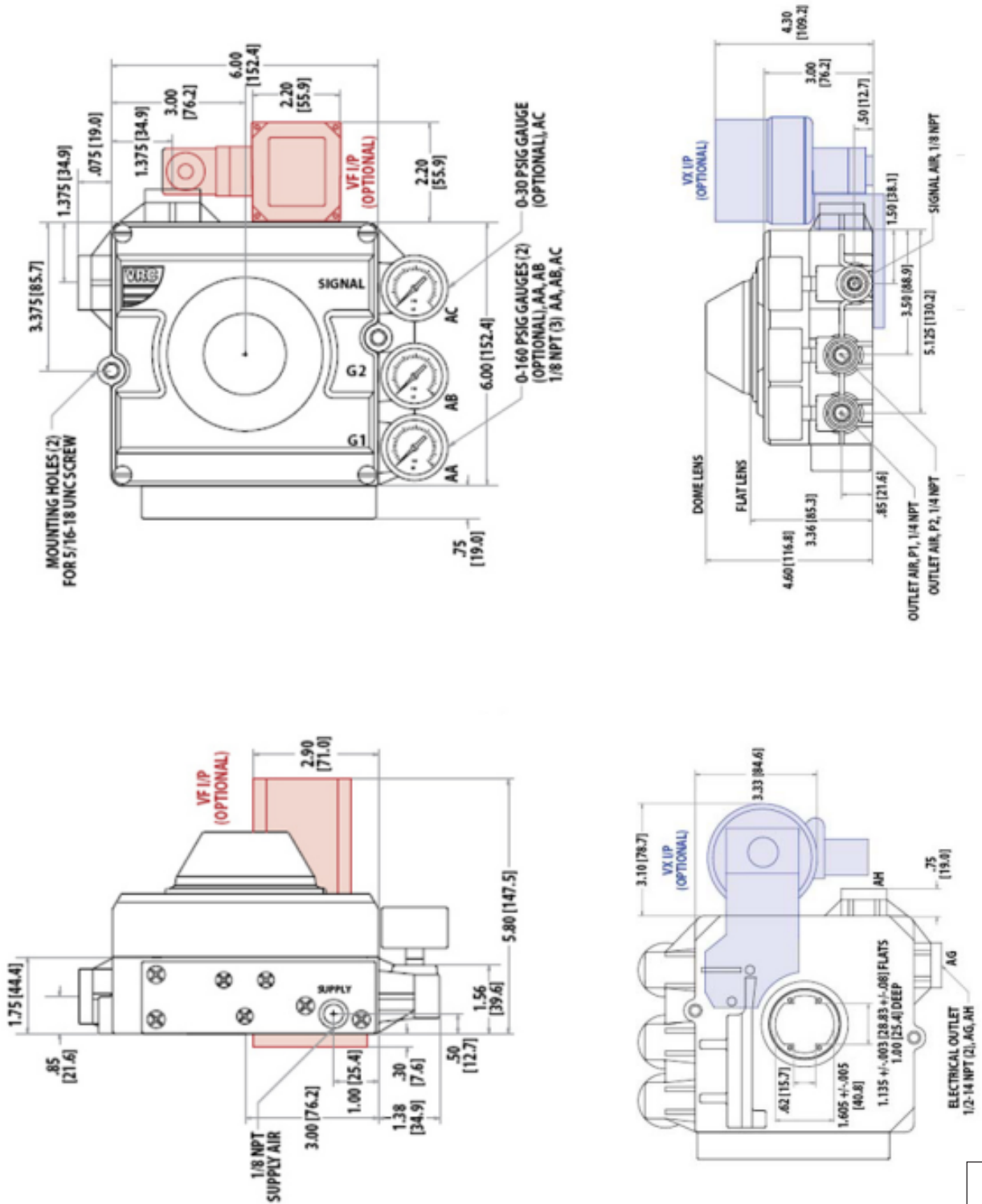

INSTALLATION PROCEDURE - VK02 I/P MODULE

MODULE FUNCTION:

The VK02 I/P Module converts a Model VP (pneumatic positioner) into a Model VE (electro-pneumatic positioner). The Model VE Positioner is designed for use in General Purpose Locations, and is NOT approved for use in Hazardous Locations as classified by the National Electrical Code.

!!WIRING MUST COMPLY WITH LOCAL CODES AND THE NATIONAL ELECTRICAL CODE (NEC).

INSTALLATION PROCEDURE:

1. Reference Figure 5
2. Turn off air supply to the Positioner.
3. Remove the cover
4. Remove (2) 1/16" NPT pipe plugs located near the SPOOL VALVE.
4. Install (2) O-Rings into O-Ring Glands (where pipe plugs were removed), provided in kit.

5. Install I/P Module using (2) captive screws provided in kit.
6. Insure SIGNAL PORT is plugged and sealed using 1/8" NPT pipe plug provided in kit.
7. Terminate field wiring as shown. NO POLARITY need be observed. The connector is removable for ease of wiring.
8. Turn on air supply and check calibration.

SPEED CONTROL JUMPERS:

1. The speed control jumpers slow the response of the Positioner to an input signal change.
2. Prior to changing the jumper selection, insure the signal input to the Positioner is set to 4 mA or LESS. **Changing the speed control jumper with more than 4mA applied will cause an immediate change in valve position.**

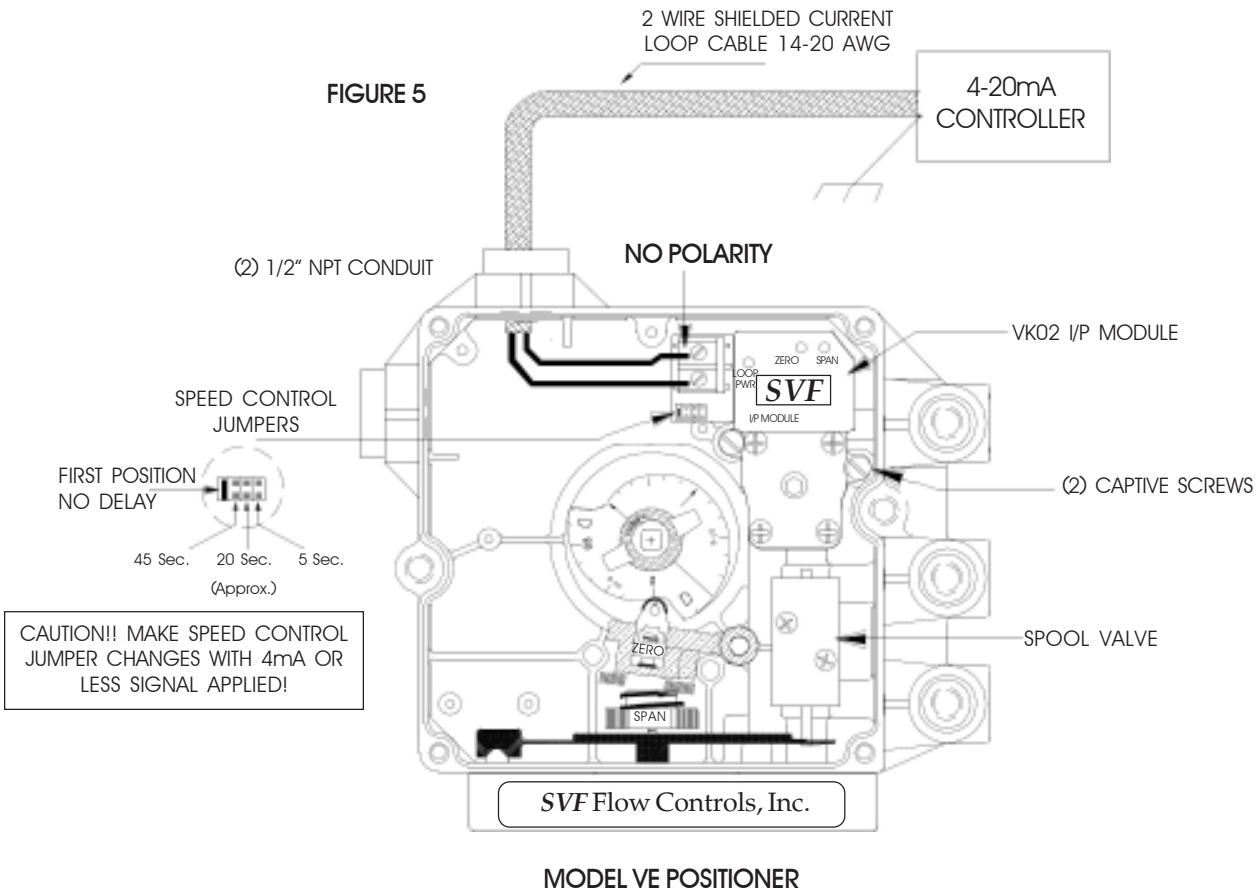



INSTALLATION PROCEDURE - VK12 I/P MODULE TYPE 22/06-65

MODULE FUNCTION

The VK12 I/P Module changes a Model VP or VE positioner into a Model VI positioner. The Model VI positioner is designed for use in General purpose and Hazardous Locations as defined by the NEC.

WIRING MUST COMPLY WITH LOCAL CODES AND THE NATIONAL ELECTRICAL CODE (NEC)

WARNING:

FOR HAZARDOUS LOCATIONS APPLICATIONS
REFERENCE CONTROL DOCUMENTS NO. 900842/900843
AVAILABLE BY CALLING VRC AT 513-677-8724/FAX 677-8731

INSTALLATION PROCEDURE

TOOLS REQUIRED: Regular slotted screwdriver,
3/16 hex key, 5/32 hex key (Allen wrenches)

Changing a Model VP into a VI Positioner

1. Reference figure below.
2. Turn off supply air to the Positioner and remove cover.
3. Remove (2) 1/16 NPT pipe plugs located near the SPOOL VALVE.

4. Install (2) o-rings into o-ring glands (where pipe plugs were removed) provided in kit.
5. Install the VK12 I/P Module using the (2) captive screws.
6. Insure SIGNAL PORT is plugged and sealed using 1/8 NPT pipe plug provided in kit.
7. Terminate field wiring.
8. Turn on supply air and check calibration.

Changing a Model VE Into a VI Positioner

1. Reference figure below.
2. Turn off supply air to the Positioner and remove cover.
3. Remove the VE I/P Module by unscrewing the (2) captive screws.
4. Install the VK12 I/P Module.
5. Insure SIGNAL PORT is plugged and sealed using 1/8 NPT pipe plug provided in kit.
6. Terminate field wiring.
7. Turn on supply air and check calibration.

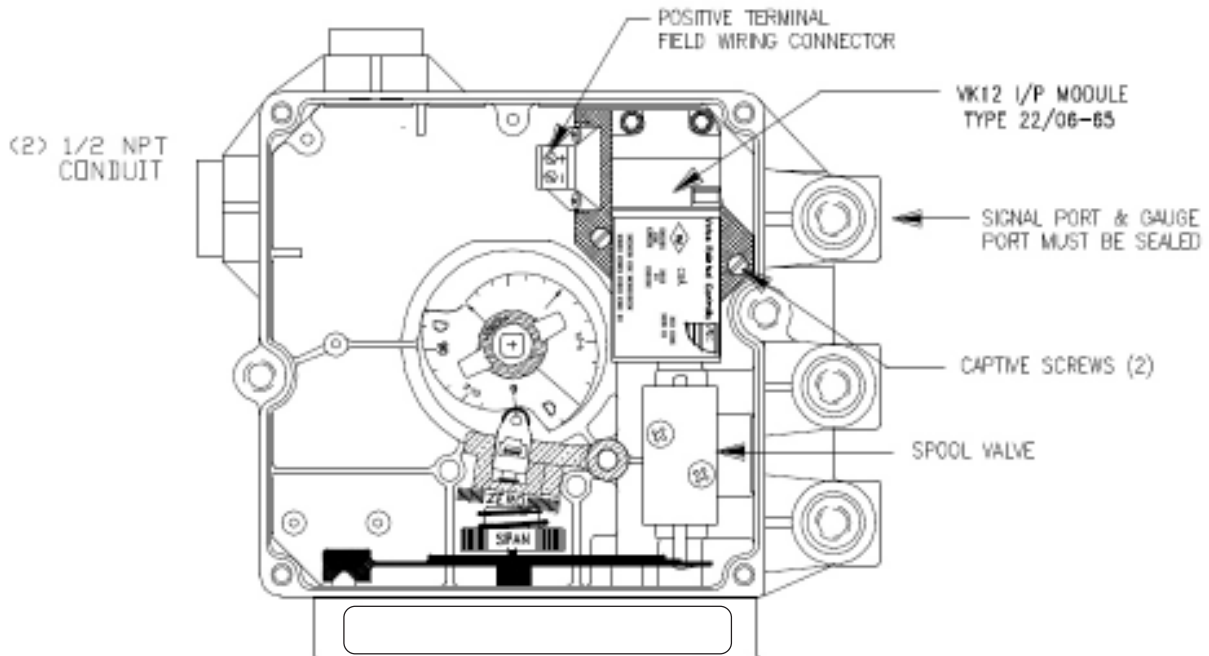

MODEL VI POSITIONER

INSTALLATION - LIMIT SWITCH MODULE

MODULE FUNCTION

The LIMIT SWITCH MODULE provides mechanical or proximity switch contacts for sensing Positioner shaft position, typically 0 and 90 degrees.

There are (2) modules available:

- S1 – mechanical switches 2 SPDT
- S2 – proximity switches 2 SPST

The Positioner can be ordered with the SWITCH MODULE and CAMS installed at the factory or S1 and S2 SWITCH MODULE kits are available for easy field installation.

INSTALLATION PROCEDURE

1. Turn off all power and supply air to the Positioner.
2. Reference Figure 6.
3. Remove the WING NUT and FEEDBACK CAM.

NOTE: Prior to removing the FEEDBACK CAM, make note of the CAM position so as to reinstall it at the same position later.

4. Slide one of the SENSOR CAMS (*spline side down*) onto the MAIN SHAFT.

5. Slide the SPRING and second SENSOR CAM (*spline side up*) onto the MAIN SHAFT.

6. Thread the LOCK NUT onto the MAIN SHAFT, (*spline side down*). Tighten securely.

7. Reinstall the FEEDBACK CAM and WING NUT.

8. Install the SWITCH MODULE.

NOTE: Insure the switch plungers (S1 only) clear the SENSOR CAMS prior to tightening the fasteners. DO NOT OVERTIGHTEN.

WIRING MUST COMPLY WITH LOCAL CODES AND THE NATIONAL ELECTRICAL CODE.

1. Attach the field wiring to the LIMIT SWITCH MODULE using the labels provided at the terminal block as a guide. Also SWITCH WIRING DIAGRAMS are included in these instructions.

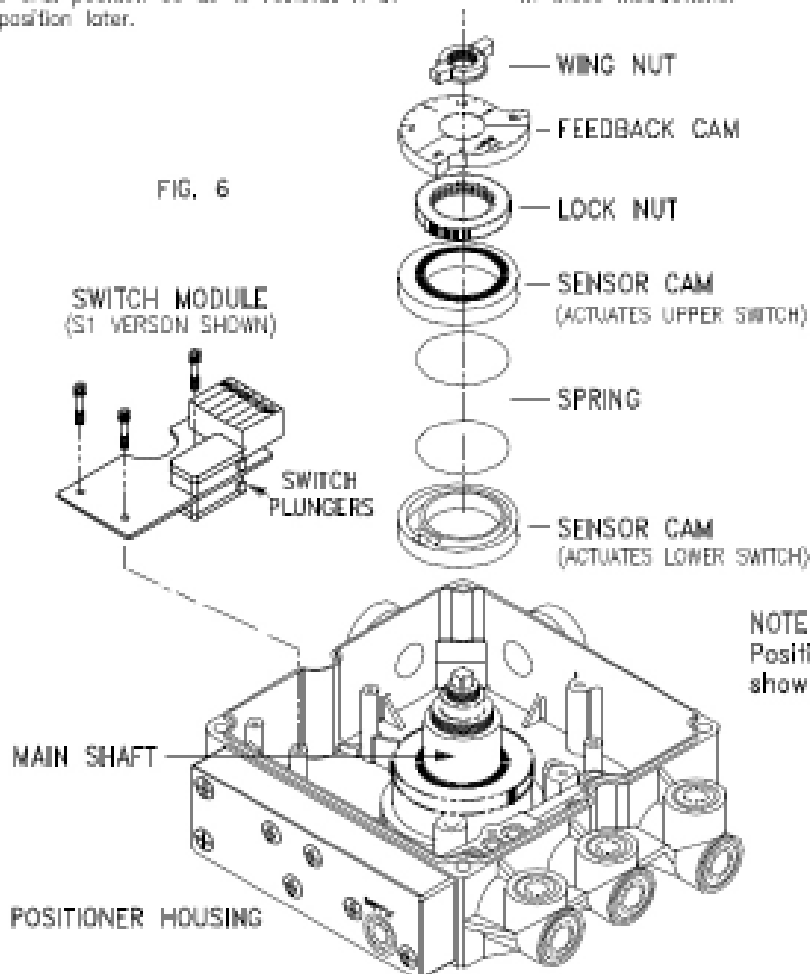

NOTE: Some internal Positioner parts not shown for clarity

LIMIT SWITCH MODULE ADJUSTMENT PROCEDURE - WIRING DIAGRAM

ADJUSTMENT PROCEDURE

This procedure assumes the Positioner is mounted on an actuator and the FEEDBACK CAM is at 0 degrees when 3 psi signal pressure is applied and rotates to 90 degrees when 15 psi signal is applied.

Each switch is independently adjusted by changing the appropriate SENSOR CAM position on the MAIN SHAFT.

MATERIAL REQUIRED: Ohmmeter or continuity tester.

1. Connect the ohmmeter to the LOWER switch terminals.

NOTE: When S1 mechanical switches are being adjusted, connect the meter to the C (common) and N.O. (normally open) terminals.

2. Turn on supply air and apply 3 psi signal air. (4MA for electro-pneumatic units)

3. Adjust the LOWER switch by lifting and rotating the LOWER SENSOR CAM until the switch indicates ON at the ohmmeter.

4. By increasing then decreasing signal air pressure insure the switch turns OFF as the actuator moves away from 0 degrees, then turns back ON as the unit rotates back toward 0 degrees.

5. Repeat steps 2, 3 and 4 as needed.

6. Change the meter connections to the UPPER switch terminals.

NOTE: When S1 mechanical switches are being adjusted, connect the meter to the C (common) and N.O. (normally open) terminals.

7. Apply 15 psi signal air.

8. Adjust the UPPER switch by depressing and rotating the UPPER SENSOR CAM until the switch indicates ON at the ohmmeter.

9. By decreasing then increasing signal air pressure, insure the switch turns OFF as the actuator moves away from 90 degrees, then turns back ON as the unit rotates back toward 90 degrees.

10. Repeat steps 7, 8 and 9 as needed.

11. As a final check, rotate the actuator through-out its range and verify the limit switches are set properly.

S1 LIMIT SWITCH MODULE
WIRING DIAGRAM

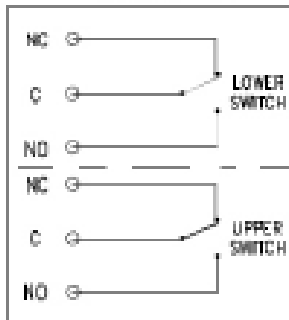

S2 LIMIT SWITCH MODULE
WIRING DIAGRAM

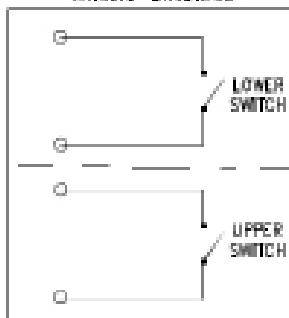

POSITIONER WITH MODULE INSTALLED

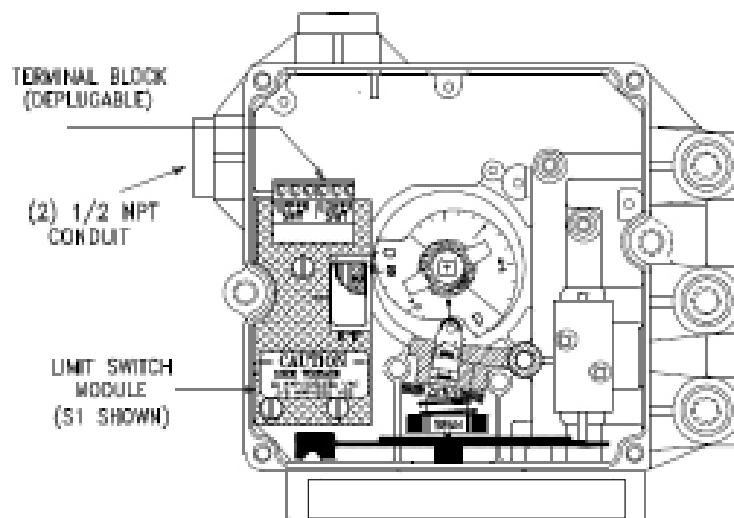

MODEL VF700-S1

INSTALLATION & CALIBRATION - T1 4-20 MILLIAMP TRANSMITTER MODULE

MODULE FUNCTION

The T1 TRANSMITTER MODULE is designed to give a 4–20 milliamp linear output signal with 0–90 degrees Positioner shaft rotation. The unit is environmentally sealed and loop powered. The T1 transmitter is designed for use in General Purpose Locations and is not approved for use in Hazardous Locations as classified by the NEC.

WIRING MUST COMPLY WITH LOCAL CODES AND THE NATIONAL ELECTRICAL CODE (NEC)

INSTALLATION PROCEDURE

1. Reference figure 7.
2. Rotate the Positioner shaft to the 0 degree point.

NOTE: Installation into a VRC model VE Positioner (electro-pneumatic) requires the I/P module be removed and reinstalled after the Transmitter has been installed.

3. Install the TRANSMITTER MODULE into the Positioner with the MODULE GEAR ARROW pointed at the Positioner MAIN SHAFT.
4. Before completely tightening the (2) captive fasteners, push the MODULE toward the MAIN SHAFT to fully engage the two gears. A loose engagement of the two gears will cause poor MODULE performance. Tighten the fasteners when the gears are fully engaged. **DO NOT OVERTIGHTEN.**

5. The MODULE has a "deplugable" wiring terminal. Pull the terminal plug loose and terminate field wiring. **NO POLARITY NEED BE OBSERVED.** Reinstall the terminal plug. The LED will light when power is applied.

CALIBRATION

1. With the Positioner at the 0 degree point on the FEEDBACK CAM, adjust the MODULE "ZERO" pot for 4 milliamp output.

2. Rotate the Positioner to the 90 degree point by applying 15 PSI signal pressure or 20 mA signal to the I/P MODULE (VE model).

3. Adjust the TRANSMITTER MODULE for 20 milliamp output by adjusting the SPAN pot.

4. Repeat steps 1 thru 3 as necessary due to interaction of ZERO and SPAN adjustments.

NOTE: The output from the TRANSMITTER MODULE is jumper selectable to give a 20 to 4 milliamp output signal with 0 to 90 degree rotation. Simply move the two (2) MODULE jumpers to the "R" position and recalibrate the ZERO pot.

NOTE: For Reverse acting applications, refer to Fig. 7A for proper orientation of the Transmitter Module gear. The Jumpers must be moved to the "R" selection also.

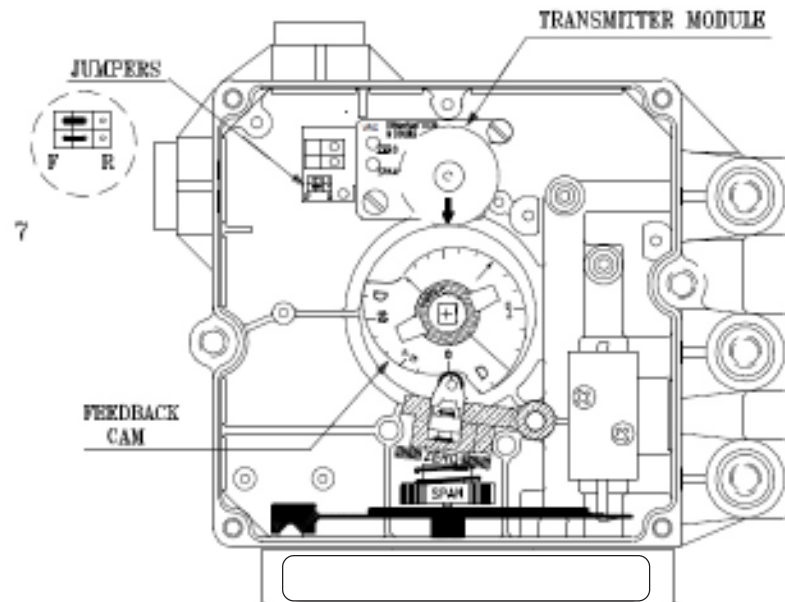

POSITIONER MODEL VP700-T1

ORIENTATION OF TRANSMITTER FOR REVERSE ACTING

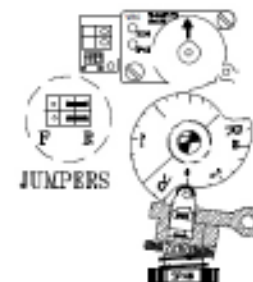
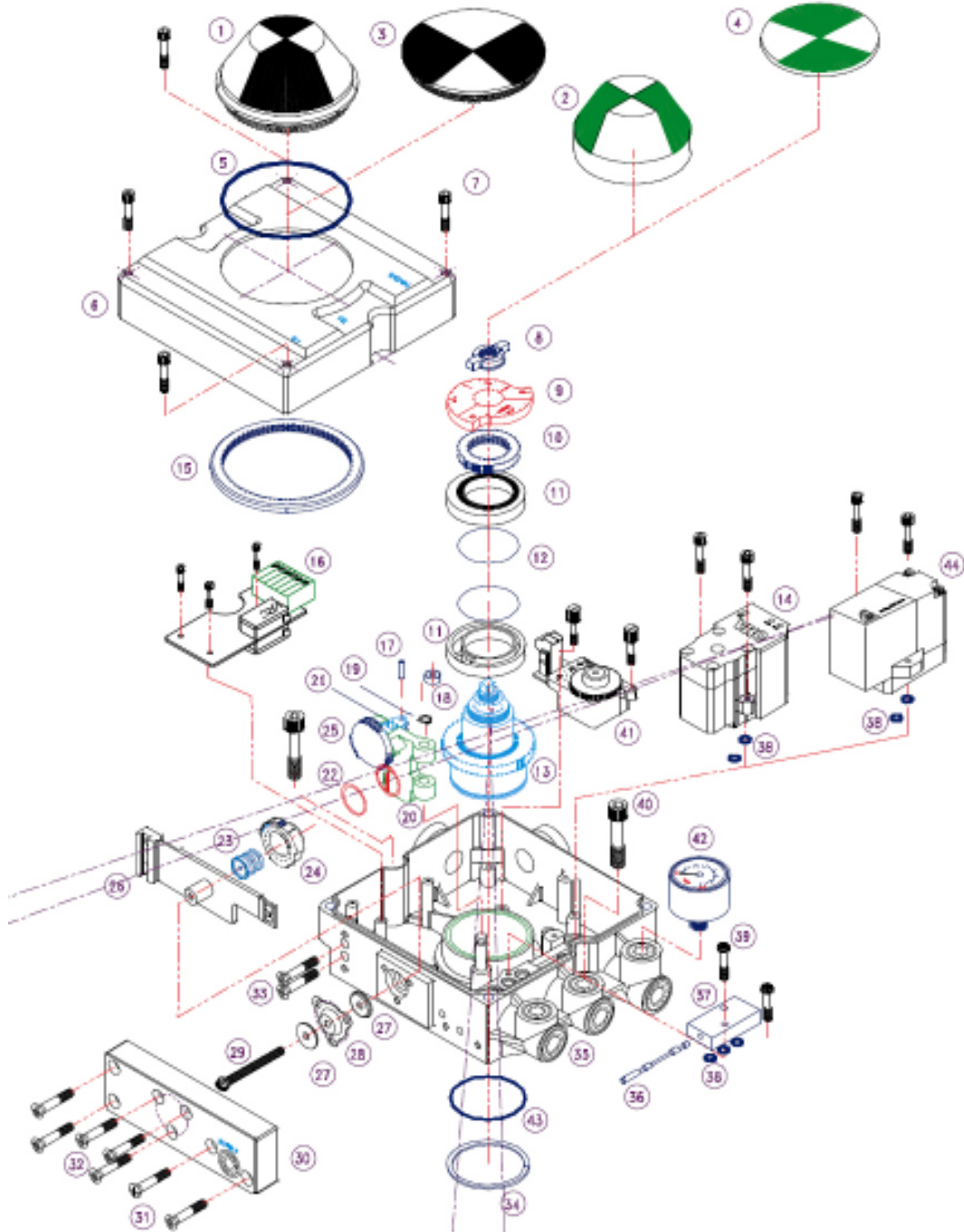

FIG. 7A

EXPLODED VIEW





PARTS LIST

VIEW NUMBER	PART NUMBER	PART DESCRIPTION	VIEW NUMBER	PART NUMBER	PART DESCRIPTION
1	VAC016	DOME LENS	28	V00013	SIGNAL DIAPHRAGM
2	VAC017	DOME INDICATOR	29	V20003	DIAPHRAGM SCREW
3	VAC018	FLAT LENS	30	VA9016	DIAPHRAGM COVER
4	VAC019	FLAT INDICATOR	31	V20013	COVER SCREW (4)
5	V00041	O-RING (2-042-N674)	32	V20028	COVER SCREW (3)
6	VAC020	COVER ASSEMBLY	33	V20012	BALANCE BEAM SCREW (2)
7	V20022	CAPTIVE COVER SCREW (4)	34	V20004	RETAINING RING
8	VM0023	WING NUT	35	VA9001	POSITIONER HOUSING
9	V10014	LINEAR FEEDBACK CAM	36	V00003	SPOOL VALVE
10	V10016	LOCK NUT	37	V00004	SPOOL VALVE BODY
11	V10015	SENSOR CAM	38	V00016	O-RING 2-010-N674
12	V00006	LIMIT SWITCH CAM SPRING	39	V20011	SPOOL VALVE SCREW (2)
13	VM0005	MAIN SHAFT	40	V20008	MOUNTING BOLT (2)
14	VK02	I/P MODULE	41	VA9021	T1 TRANSMITTER
15	V10017	LENS RETAINING RING	42	V00034	PRESSURE GAUGE
16	VAC012	LIMIT SWITCH MODULE	43	V00044	O-RING 2-028-N674
17	V20049	DOWEL PIN	44	VK12	I/P MODULE (TYPE 22/06) INTRINSICALLY SAFE/NON-INCENDIVE
18	V00063	BEARING			
19	V20005	SNAP RING			
20	VA9007	CAM FOLLOWER ASSEMBLY			
21	VA0025	BEARING HOLDER ASSEMBLY			
22	V00062	FEEDBACK SPRING			
23	VA0026	SPAN CARRIER ASSEMBLY			
24	VAC009	SPAN ADJUSTER			
25	VAC008	ZERO ADJUSTER			
26	VM0006	BALANCE BEAM			
27	V10010	WASHER (2)			

RECOMMENDED SPARE PARTS	
PART NUMBER	DESCRIPTION
VA9005	MAIN SHAFT ASSEMBLY
VA9007	CAM FOLLOWER ASSEMBLY
VA9010	SIGNAL DIAPHRAGM ASSEMBLY
VA9016	DIAPHRAGM COVER ASSEMBLY
VM0006	BALANCE BEAM
VK00	SPOOL VALVE ASSEMBLY (STD)
VK02	I/P MODULE KIT
V00016	O-RING 2-010-N674